



SWIFT
CREATING SMILES FOR LIFE

Swift Group Technical Handbook

Caravans

Issued August 2021

Part No. 1442594

Contents

Basecamp Specification	4
Sprite Specification	6
Sprite Super Specification	8
Challenger Specification	10
Challenger X Specification	12
Conqueror Specification	14
Elegance Specification	16
Wiring Diagrams - Road Lighting	18
Wiring Diagrams - Consumer Circuits	21
Wiring Diagrams - Consumer Circuits - Roof	24
Wiring Diagrams - Power Circuits	27
Wiring Diagrams - 230V Circuits	31
Wiring Diagrams - 13 Pin Socket	32
Wiring Diagrams - Cable Colour Chart	33
Bulb Replacement	34
Dealer Special specifications based on Sprite	36
Dealer Special specifications based on Sprite Super	38
Dealer Special specifications based on Challenger	40
Dealer Special specifications based on Challenger X	42
Dealer Special specification based on Conqueror	44
Dealer Special specification based on Elegance	46
Bed make up	47

Basecamp Specification

Basecamp	Basecamp 2	Basecamp 4
Berths	2	4
Axles	1	1
Internal Length (bed box height)	3.42m / 11'3"	3.91m / 12'10"
Overall Width**	2.28m / 7'6"	2.28m / 7'6"
Overall Height (inc. TV Aerial)**	2.60m / 8'6"	2.61m / 8'7"
Maximum Internal Headroom	1.95m / 6'5"	1.95m / 6'5"
Overall Length**	5.10m / 16'9"	5.59m / 18'4"
Mass in Running Order (inc. tolerance)	932kg / 18.3cwt	1050kg / 20.7cwt
Maximum Technical Permissible Laden Mass (Lower limit)	1043kg / 20.5cwt	1186kg / 23.3cwt
Maximum Technical Permissible Laden Mass (Upper limit)	1300kg / 25.6cwt	1450kg / 28.5cwt
Total user Payload	111kg / 2.2cwt	136kg / 2.7cwt
Personal Effects	111kg / 2.2cwt	136kg / 2.7cwt
Options	0kg / 0.0cwt	0kg / 0.0cwt
Tyre Size	185 R14C 102	185 R14C 102
Tyre pressure at Lower limit MTPLM	3.4 bar / 49 psi	3.4 bar / 49 psi
Tyre pressure at Upper limit MTPLM	3.7 bar / 54 psi	4.2 bar / 61 psi
Static Load on Coupling Head	100kg	100kg
Thermal Insulation Grade	THREE	THREE
Bed Sizes		
Front Double	198cm x 183cm / 6'6" x 6'0"	198cm x 130cm / 6'6" x 4'3"
or Front Nearside Single	183cm x 69cm / 6'0" x 2'3"	
and Front Offside Single	183cm x 69cm / 6'0" x 2'3"	
Side Bunk Nearside (upper)		178cm x 54cm / 5'10" x 1'9"
Side Bunk Nearside (lower)		178cm x 54cm / 5'10" x 1'9"
Side Bunk Offside (upper)		
Side Bunk Offside (lower)		

Masses: The masses are calculated in accordance to EU regulation 1230 / 2012 and NCC code of practice 304.

The Mass in Running Order (MRO) comprises:

1. The mass of the empty caravan as supplied by Swift including loose items such as the hook-up cable, kit bag, entrance step, manuals etc.
2. 10kg allowance for LPG

The MRO is calculated with the fresh water tank, toilet flush tank and water heater empty. If you travel with water in the fresh water tank, toilet flush tank and the water heater the payload will reduce accordingly.

The personal effects is based on the number of berths and the length of the caravan and includes an allowance of 20kg for a leisure battery.

The Maximum Technical Laden Mass (MTPLM) is the maximum mass allowed when the caravan is fully laden.

WARNING: Under no circumstances should the MTPLM be exceeded

Basecamp 6
6
1
4.88m / 16'0
2.28m / 7'6"
2.62 / 8'7"
1.98m / 6'6"
6.57m / 21'7"
1165kg / 22.9cwt
1331kg / 26.2cwt
1500kg / 29.5cwt
166kg / 3.3cwt
166kg / 3.3cwt
0kg / 0.0cwt
185 R14C 102
3.8 bar / 55 psi
4.4 bar / 64 psi
100kg
THREE
198cm x 130cm / 6'6" x 4'3"
178cm x 54cm / 5'10" x 1'9"
178cm x 54cm / 5'10" x 1'9"
178cm x 54cm / 5'10" x 1'9"
178cm x 54cm / 5'10" x 1'9"

Bed Sizes: Please note that the front double bed sizes quoted are for seating configurations without chest of drawers. The front double bed width for a layout with a chest of drawers fitted will be reduced by 0.4m (1'4") from that stated.

Awning sizes: Due to the varying awning designs and sizes the awning sizes given are approximate only. Specific awning sizes must be confirmed by your dealer or the awning manufacturer prior to purchase.

Est = Estimated weight or bed size

**The dimensions given are approximate due to slight variations in suspension ride heights, loading conditions and tyre pressures.

Customers should verify the actual dimensions of their touring caravan before committing to anything that could be impacted by these dimensions

Please note: Any dealer fit options will reduce the overall payload available to the user of the caravan.

If you require additional payload it is possible to upgrade the MTPLM to the upper limit. Please contact your caravan dealer for more information.

Sprite Specification

Sprite	Compact	Alpine 2	Alpine 4	Major 4 SB
Berths	2	2	4	4
Axles	1	1	1	1
Internal Length (bed box height)	3.66m / 12'0"	4.34m / 14'3"	4.74m / 15'7"	5.83m / 19'2"
Overall Width**	2.03m / 6'8"	2.25m / 7'5"	2.25m / 7'5"	2.25m / 7'5"
Overall Height (inc. TV Aerial)**	2.59m / 8'6"	2.59m / 8'6"	2.59m / 8'6"	2.59m / 8'6"
Maximum Internal Headroom	1.95m / 6'5"	1.95m / 6'5"	1.95m / 6'5"	1.95m / 6'5"
Overall Length**	5.37m / 17'7"	6.05m / 19'10"	6.45m / 21'2"	7.54m / 24'9"
Awning A / A dimension	7.95m / 26'1"	8.59m / 28'2"	8.99m / 29'6"	10.08m / 33'1"
Mass in Running Order (inc. tolerance)	980kg / 19.3cwt	1097kg / 21.6cwt	1139kg / 22.4cwt	1286kg / 25.3cwt
Maximum Technical Permissible Laden Mass (Lower limit)	1094kg / 21.5cwt	1218kg / 24.0cwt	1284kg / 25.3cwt	1442kg / 28.4cwt
Maximum Technical Permissible Laden Mass (Upper limit)	1200kg / 23.6cwt	1250kg / 24.6cwt	1300kg / 25.6cwt	1500kg / 29.5cwt
Total user Payload	114kg / 2.2cwt	121kg / 2.4cwt	145kg / 2.9cwt	156kg / 3.1cwt
Personal Effects	114kg / 2.2cwt	121kg / 2.4cwt	145kg / 2.9cwt	156kg / 3.1cwt
Options	0kg / 0.0cwt	0kg / 0.0cwt	0kg / 0.0cwt	0kg / 0.0cwt
Tyre Size	185 R14C 102 Q	185 R14C 102 Q	185 R14C 102Q	185 R14C 102Q
Tyre pressure at Lower limit MTPLM	3.4bar / 49psi	3.4 bar / 49 psi	3.6 bar / 52 psi	4.2 bar / 61 psi
Tyre pressure at Upper limit MTPLM	3.4 bar / 49psi	3.5 bar / 51 psi	3.7 bar / 54 psi	4.4 bar / 64 psi
Static Load on Coupling Head	100kg	100kg	100kg	100kg
Thermal Insulation Grade	THREE	THREE	THREE	THREE
Bed Sizes				
Front Double	182cm x 180cm / 6'0" x 5'11"	202cm x 180cm / 6'8" x 5'11"	202cm x 128cm / 6'8" x 4'2"	202cm x 159cm / 6'8" x 5'3"
or Front Nearside Single	180cm x 65cm / 5'11" x 2'2"	190cm x 72cm / 6'3" x 2'4"		159cm x 72cm / 5'3" x 2'4"
and Front Offside Single	180cm x 65cm / 5'11" x 2'2"	180cm x 72cm / 5'11" x 2'4"		159cm x 72cm / 5'3" x 2'4"
Rear Double			189cm x 132cm / 6'2" x 4'4"	185cm x 133cm / 6'1" x 4'4"
Side Single (offside)				
Side Single (nearside)				
Side Bunk (offside)				
Side Bunk (nearside)				
Side Fixed Lower Bunk				
Side Fixed Upper Bunk				

Masses: The masses are calculated in accordance to EU regulation 1230 / 2012 and NCC code of practice 304.

The Mass in Running Order (MRO) comprises:

1. The mass of the empty caravan as supplied by Swift including loose items such as the hook-up cable, kit bag, entrance step, manuals etc.
2. 10kg allowance for LPG

The MRO is calculated with the fresh water tank, toilet flush tank and water heater empty. If you travel with water in the fresh water tank, toilet flush tank and the water heater the payload will reduce accordingly.

The personal effects is based on the number of berths and the length of the caravan and includes an allowance of 20kg for a leisure battery.

The Maximum Technical Laden Mass (MTPLM) is the maximum mass allowed when the caravan is fully laden.

WARNING: Under no circumstances should the MTPLM be exceeded

Major 4 EB	Major 6 TD	Quattro EW	Quattro FB
4	6	6	6
1	1	2	2
5.83m / 19'2"	5.83m / 19'2"	6.27m / 20'7"	6.27m / 20'7"
2.25m / 7'5"	2.25m / 7'5"	2.25m / 7'5"	2.25m / 7'5"
2.59m / 8'6"	2.59m / 8'6"	2.59m / 8'6"	2.59m / 8'6"
1.95m / 6'5"	1.95m / 6'5"	1.95m / 6'5"	1.95m / 6'5"
7.54m / 24'9"	7.54m / 24'9"	7.98m / 26'2"	7.98m / 26'2"
10.08m / 33'1"	10.08m / 33'1"	10.52m / 34'6"	10.52m / 34'6"
1320kg / 26.0cwt	1352kg / 26.6cwt	1430kg / 28.1cwt	1450kg / 28.5cwt
1476kg / 29.1cwt	1528kg / 30.1cwt	1610kg / 31.7cwt	1630kg / 32.1cwt
1500kg / 29.5cwt	1550kg / 30.5cwt	1800kg / 35.4cwt	1800kg / 35.4cwt
156kg / 3.1cwt	176kg / 3.5cwt	180kg / 3.5cwt	180kg / 3.5cwt
156kg / 3.1cwt	176kg / 3.5cwt	180kg / 3.5cwt	180kg / 3.5cwt
0kg / 0.0cwt	0kg / 0.0cwt	0kg / 0.0cwt	0kg / 0.0cwt
185 R14C 102Q	185 R14C 102Q	185 / 70 R14 88T	185 / 70 R14 88T
4.3 bar / 62 psi	4.5 bar / 65 psi	2.0 bar / 29 psi	2.0 bar / 29 psi
4.4 bar / 64 psi	4.5 bar / 65 psi	2.2 bar / 32 psi	2.2 bar / 32 psi
100kg	100kg	100kg	100kg
THREE	THREE	THREE	THREE
202cm x 159cm / 6'8" x 5'3"	202cm x 180cm / 6'8" x 5'11"	206cm x 134cm / 6'9" x 4'5"	202cm x 180cm / 6'8" x 5'11"
159cm x 72cm / 5'3" x 2'4"	190cm x 72cm / 6'3" x 2'4"		180cm x 72cm / 5'11" x 2'4"
159cm x 72cm / 5'3" x 2'4"	180cm x 72cm / 5'11" x 2'4"		190cm x 72cm / 6'3" x 2'4"
190cm x 133cm / 6'3" x 4'4"		194cm x 132cm / 6'4" x 4'4"	192cm x 132cm / 6'4" x 4'4"
		180cm x 62cm / 5'11" x 2'0"	180cm x 62cm / 5'11" x 2'0"
	180cm x 67cm / 5'11" x 2'2"		
		176cm x 59cm / 5'9" x 1'11"	176cm x 59cm / 5'9" x 1'11"
	176cm x 59cm / 5'9" x 1'11"		
	183cm x 57cm / 6'0" x 1'10"		
	183cm x 57cm / 6'0" x 1'10"		

Bed Sizes: Please note that the front double bed sizes quoted are for seating configurations without chest of drawers. The front double bed width for a layout with a chest of drawers fitted will be reduced by 0.4m (1'4") from that stated.

Awning sizes: Due to the varying awning designs and sizes the awning sizes given are approximate only. Specific awning sizes must be confirmed by your dealer or the awning manufacturer prior to purchase.

Est = Estimated weight or bed size

**The dimensions given are approximate due to slight variations in suspension ride heights, loading conditions and tyre pressures.

Customers should verify the actual dimensions of their touring caravan before committing to anything that could be impacted by these dimensions

Please note: Any dealer fit options will reduce the overall payload available to the user of the caravan.

If you require additional payload it is possible to upgrade the MTPLM to the upper limit. Please contact your caravan dealer for more information.

Sprite Super Specification

Sprite Super	Major 4 SB	Quattro FB	Quattro DB
Berths	4	6	6
Axles	1	2	2
Internal Length (bed box height)	5.83m / 19' 2"	6.27m / 20' 7"	6.27m / 20' 7"
Overall Width**	2.46m / 8'1"	2.46m / 8'1"	2.46m / 8'1"
Overall Height (inc. TV Aerial)**	2.61m / 8'7"	2.59m / 8'6"	2.59m / 8'6"
Maximum Internal Headroom	1.95m / 6'5"	1.95m / 6'5"	1.95m / 6'5"
Overall Length**	7.54m / 24' 9"	7.98m / 26' 2"	7.98m / 26' 2"
Awning A / A dimension	10.20m / 33'6"	10.56m / 34'8"	10.56m / 34'8"
Mass in Running Order (inc. tolerance)	1390kg / 27.4cwt	1524kg / 30.0cwt	1530kg / 30.1cwt
Maximum Technical Permissible Laden Mass (Lower limit)	1546kg / 30.4cwt	1704kg / 33.5cwt	1710kg / 33.7cwt
Maximum Technical Permissible Laden Mass (Upper limit)	1650kg / 32.5cwt	1800kg / 35.4cwt	1800kg / 35.4cwt
Total user Payload	156kg / 3.1cwt	180kg / 3.5cwt	180kg / 3.5cwt
Personal Effects	156kg / 3.1cwt	180kg / 3.5cwt	180kg / 3.5cwt
Options	0kg / 0.0cwt	0kg / 0cwt	0kg / 0cwt
Tyre Size	195/70 R15C 104 R	185 / 70 R14 88T	185 / 70 R14 88T
Tyre pressure at Lower limit MTPLM	4.2 bar / 61 psi	2.0 bar / 29 psi	2.0 bar / 29 psi
Tyre pressure at Upper limit MTPLM	4.5 bar / 65 psi	2.2 bar / 32 psi	2.2 bar / 32 psi
Static Load on Coupling Head	100kg	100kg	100kg
Thermal Insulation Grade	THREE	THREE	THREE
Bed Sizes			
Front Double	225cm x 163cm / 7'4" x 5'4"	225cm x 180cm / 7'4" x 5'11"	225cm x 180cm / 7'4" x 5'11"
or Front Nearside Single	163cm x 73cm / 5'4" x 2'5"	180cm x 73cm / 5'11" x 2'5"	180cm x 73cm / 5'11" x 2'5"
and Front Offside Single	163cm x 73cm / 5'4" x 2'5"	180cm x 73cm / 5'11" x 2'5"	180cm x 73cm / 5'11" x 2'5"
Rear Double	185cm x 133cm / 6'1" x 4'4"	196cm x 135cm / 6'5" x 4'5"	190cm x 134cm / 6'3" x 4'5"
Side Double (offside)		190cm x 134cm / 6'3" x 4'5"	190cm x 134cm / 6'3" x 4'5"
Side Fixed Lower Bunk			182cm x 72cm / 6'0" x 2'4"
Side Fixed Upper Bunk			182cm x 72cm / 6'0" x 2'4"

Masses: The masses are calculated in accordance to EU regulation 1230 / 2012 and NCC code of practice 304.

The Mass in Running Order (MRO) comprises:

1. The mass of the empty caravan as supplied by Swift including loose items such as the hook-up cable, kit bag, entrance step, manuals etc.
2. 10kg allowance for LPG

The MRO is calculated with the fresh water tank, toilet flush tank and water heater empty. If you travel with water in the fresh water tank, toilet flush tank and the water heater the payload will reduce accordingly.

The personal effects is based on the number of berths and the length of the caravan and includes an allowance of 20kg for a leisure battery.

The Maximum Technical Laden Mass (MTPLM) is the maximum mass allowed when the caravan is fully laden.

WARNING: Under no circumstances should the MTPLM be exceeded

Bed Sizes: Please note that the front double bed sizes quoted are for seating configurations without chest of drawers. The front double bed width for a layout with a chest of drawers fitted will be reduced by 0.4m (1'4") from that stated.

Awning sizes: Due to the varying awning designs and sizes the awning sizes given are approximate only. Specific awning sizes must be confirmed by your dealer or the awning manufacturer prior to purchase.

Est = Estimated weight or bed size

**The dimensions given are approximate due to slight variations in suspension ride heights, loading conditions and tyre pressures.

Customers should verify the actual dimensions of their touring caravan before committing to anything that could be impacted by these dimensions

Please note: Any dealer fit options will reduce the overall payload available to the user of the caravan.

If you require additional payload it is possible to upgrade the MTPLM to the upper limit. Please contact your caravan dealer for more information.



Challenger Specification

Challenger	480	530	560
Berths	2	4	4
Axles	1	1	1
Internal Length (bed box height)	4.95m / 16'3"	5.29m / 17'4"	5.83m / 19'2"
Overall Width**	2.23m / 7'4"	2.23m / 7'4"	2.23m / 7'4"
Overall Height (inc. TV Aerial)**	2.61m / 8'7"	2.61m / 8'7"	2.61m / 8'7"
Maximum Internal Headroom	1.95m / 6'5"	1.95m / 6'5"	1.95m / 6'5"
Overall Length**	6.66m / 21'10"	7.00m / 23'0"	7.54m / 24'9"
Awning A / A dimension	9.32m / 30'7"	9.66m / 31'8"	10.20m / 33'6"
Mass in Running Order (inc. tolerance)	1267kg / 24.9cwt	1330kg / 26.2cwt	1394kg / 27.4cwt
Maximum Technical Permissible Laden Mass (Lower limit)	1394kg / 27.4cwt	1481kg / 29.2cwt	1550kg / 30.5cwt
Maximum Technical Permissible Laden Mass (Upper limit)	1500kg / 29.5cwt	1500kg / 29.5cwt	1550kg / 30.5cwt
Total user Payload	127kg / 2.5cwt	151kg / 3.0cwt	156kg / 3.1cwt
Personal Effects	127kg / 2.5cwt	151kg / 3.0cwt	156kg / 3.1cwt
Options	0.0kg / 0.0cwt	0.0kg / 0.0cwt	0.0kg / 0.0cwt
Tyre Size	185 R14C 102Q	185 R14C 102Q	185 R14C 102Q
Tyre pressure at Lower limit MTPLM	4.0 bar / 58 psi	4.3 bar / 62 psi	4.5 bar / 65 psi
Tyre pressure at Upper limit MTPLM	4.4 bar / 64 psi	4.4 bar / 64 psi	4.5 bar / 65 psi
Static Load on Coupling Head	100kg	100kg	100kg
Thermal Insulation Grade	THREE	THREE	THREE
Bed Sizes			
Front Double	202cm x 186cm / 6'8" x 6'1"	202cm x 176cm / 6'8" x 5'9"	202cm x 156cm / 6'8" x 5'1"
or Front Nearside Single and Front Offside Single	196cm x 72cm / 6'4" x 2'4"	176cm x 72cm / 5'9" x 2'4"	156cm x 72cm / 5'1" x 2'4"
Rear Double	186cm x 72cm / 6'1" x 2'4"	186cm x 72cm / 6'1" x 2'4"	156cm x 72cm / 5'1" x 2'4"
Side Single (offside)		180cm x 62cm / 5'11" x 2'0"	190cm x 133cm / 6'3" x 4'4"
Side Bunk (offside)		176cm x 59cm / 5'9" x 1'11"	

Masses: The masses are calculated in accordance to EU regulation 1230 / 2012 and NCC code of practice 304.

The Mass in Running Order (MRO) comprises:

1. The mass of the empty caravan as supplied by Swift including loose items such as the hook-up cable, kit bag, entrance step, manuals etc.
2. 10kg allowance for LPG

The MRO is calculated with the fresh water tank, toilet flush tank and water heater empty. If you travel with water in the fresh water tank, toilet flush tank and the water heater the payload will reduce accordingly.

The personal effects is based on the number of berths and the length of the caravan and includes an allowance of 20kg for a leisure battery.

The Maximum Technical Laden Mass (MTPLM) is the maximum mass allowed when the caravan is fully laden.

WARNING: Under no circumstances should the MTPLM be exceeded

580	650
4	4
1	2
5.83m / 19'2"	6.27m / 20'7"
2.23m / 7'4"	2.23m / 7'4"
2.61m / 8'7"	2.61m / 8'7"
1.95m / 6'5"	1.95m / 6'5"
7.54m / 24'9"	7.98m / 26'2"
10.20m / 33'6"	10.52m / 34'6"
1367kg / 26.9cwt	1549kg / 30.5cwt
1523kg / 30.0cwt	1709kg / 33.6cwt
1550kg / 30.5cwt	2000kg / 39.4cwt
156kg / 3.1cwt	160kg / 3.1cwt
156kg / 3.1cwt	160kg / 3.1cwt
0.0kg / 0.0cwt	0.0kg / 0.0cwt
185 R14C 102Q	185 / 70 R14 88T
4.5 bar / 65 psi	2.1 bar / 30 psi
4.5 bar / 65 psi	2.5 bar / 36 psi
100kg	100kg
THREE	THREE
202cm x 156cm / 6'8" x 5'1"	202cm x 156cm / 6'8" x 5'1"
156cm x 72cm / 5'1" x 2'4"	156cm x 72cm / 5'1" x 2'4"
156cm x 72cm / 5'1" x 2'4"	156cm x 72cm / 5'1" x 2'4"
185cm x 133cm / 6'1" x 4'4"	185cm x 133cm / 6'1" x 4'4"

Bed Sizes: Please note that the front double bed sizes quoted are for seating configurations without chest of drawers. The front double bed width for a layout with a chest of drawers fitted will be reduced by 0.4m (1'4") from that stated.

Awning sizes: Due to the varying awning designs and sizes the awning sizes given are approximate only. Specific awning sizes must be confirmed by your dealer or the awning manufacturer prior to purchase.

Est = Estimated weight or bed size

**The dimensions given are approximate due to slight variations in suspension ride heights, loading conditions and tyre pressures.

Customers should verify the actual dimensions of their touring caravan before committing to anything that could be impacted by these dimensions

Please note: Any dealer fit options will reduce the overall payload available to the user of the caravan.

If you require additional payload it is possible to upgrade the MTPLM to the upper limit. Please contact your caravan dealer for more information.

Challenger X Specification

Challenger X	860	880	835
Berths	4	4	4
Axles	1	1	2
Internal Length (bed box height)	5.83m / 19'2"	5.83m / 19'2"	6.27m / 20'7"
Overall Width**	2.45m / 8'0"	2.45m / 8'0"	2.45m / 8'0"
Overall Height (inc. TV Aerial)**	2.61m / 8'7"	2.61m / 8'7"	2.59m / 8'6"
Maximum Internal Headroom	1.95m / 6'5"	1.95m / 6'5"	1.95m / 6'5"
Overall Length**	7.54m / 24'9"	7.54m / 24'9"	7.98m / 26'2"
Awning A / A dimension	10.20m / 33'6"	10.20m / 33'6"	10.52m / 34'6"
Mass in Running Order (inc. tolerance)	1504kg / 29.6cwt Est	1460kg / 28.7cwt	1621kg / 31.9cwt
Maximum Technical Permissible Laden Mass (Lower limit)	1660kg / 32.7cwt Est	1616kg / 31.8cwt	1781kg / 35.1cwt
Maximum Technical Permissible Laden Mass (Upper limit)	1750kg / 34.4cwt	1750kg / 34.4cwt	2000kg / 39.4cwt
Total user Payload	156kg / 3.1cwt	156kg / 3.1cwt	160kg / 3.1cwt
Personal Effects	156kg / 3.1cwt	156kg / 3.1cwt	160kg / 3.1cwt
Options	0.0kg / 0.0cwt	0.0kg / 0.0cwt	0.0kg / 0.0cwt
Tyre Size	195 / 70 R15C 104 R	195 / 70 R15C 104 R	185 / 70 R14 88 T
Tyre pressure at Lower limit MTPLM	4.5 bar / 65 psi	4.5 bar / 65 psi	2.2 bar / 32 psi
Tyre pressure at Upper limit MTPLM	4.5 bar / 65 ps	4.5 bar / 65 psi	2.5 bar / 36 psi
Static Load on Coupling Head	100kg	100kg	100kg
Thermal Insulation Grade	THREE	THREE	THREE
Bed Sizes			
Front Double	197cm x 127cm / 6'6" x 4'2"	225cm x 159cm / 7'4" x 5'3"	225cm x 159cm / 7'4" x 5'3"
or Front Nearside Single and Front Offside Single		159cm x 73cm / 5'3" x 2'5"	159cm x 73cm / 5'3" x 2'5"
Rear Double	187cm x 143cm / 6'2" x 4'8"	187cm x 133cm / 6'2" x 4'4"	187cm x 133cm / 6'2" x 4'4"
Side Single (offside)			
Side Single (nearside)			
Side Bunk (offside)			
Side Bunk (nearside)			
Side Fixed Lower Bunk			
Side Fixed Upper Bunk			

Masses: The masses are calculated in accordance to EU regulation 1230 / 2012 and NCC code of practice 304.

The Mass in Running Order (MRO) comprises:

1. The mass of the empty caravan as supplied by Swift including loose items such as the hook-up cable, kit bag, entrance step, manuals etc.
2. 10kg allowance for LPG

The MRO is calculated with the fresh water tank, toilet flush tank and water heater empty. If you travel with water in the fresh water tank, toilet flush tank and the water heater the payload will reduce accordingly.

The personal effects is based on the number of berths and the length of the caravan and includes an allowance of 20kg for a leisure battery.

The Maximum Technical Laden Mass (MTPLM) is the maximum mass allowed when the caravan is fully laden.

WARNING: Under no circumstances should the MTPLM be exceeded

850
4
2
6.27m / 20'7"
2.45m / 8'0"
2.59m / 8'6"
1.95m / 6'5"
7.98m / 26'2"
10.52m / 34'6"
1639kg / 32.3cwt
1799kg / 35.4cwt
2000.0kg / 39.4cwt
160kg / 3.1cwt
160kg / 3.1cwt
0.0kg / 0.0cwt
185 / 70 R14 88 T
2.2 bar / 32 psi
2.5 bar / 36 psi
100kg
THREE
197cm x 127cm / 6'6" x 4'2"
187cm x 143cm / 6'2" x 4'8"

Bed Sizes: Please note that the front double bed sizes quoted are for seating configurations without chest of drawers. The front double bed width for a layout with a chest of drawers fitted will be reduced by 0.4m (1'4") from that stated.

Awning sizes: Due to the varying awning designs and sizes the awning sizes given are approximate only. Specific awning sizes must be confirmed by your dealer or the awning manufacturer prior to purchase.

Est = Estimated weight or bed size

**The dimensions given are approximate due to slight variations in suspension ride heights, loading conditions and tyre pressures.

Customers should verify the actual dimensions of their touring caravan before committing to anything that could be impacted by these dimensions

Please note: Any dealer fit options will reduce the overall payload available to the user of the caravan.

If you require additional payload it is possible to upgrade the MTPLM to the upper limit. Please contact your caravan dealer for more information.

Conqueror Specification

Conqueror	480	560	565
Berths	2	4	4
Axles	1	1	1
Internal Length (bed box height)	4.98m / 16'4"	5.93m / 19'5"	5.93m / 19'5"
Overall Width*	2.28m / 7'6"	2.28m / 7'6"	2.28m / 7'6"
Overall Height (inc. TV Aerial)*	2.59m / 8'6"	2.61m / 8'7"	2.61m / 8'7"
Maximum Internal Headroom	1.95m / 6'5"	1.95m / 6'5"	1.95m / 6'5"
Overall Length*	6.59m / 21'7"	7.54m / 24'9"	7.54m / 24'9"
Awning A / A dimension	9.28m / 30'5"	10.30m / 33'10"	10.30m / 33'10"
Mass in Running Order (inc. tolerance)	1351kg / 26.6cwt	1558kg / 30.7cwt	1545kg / 30.4cwt
Maximum Technical Permissible Laden Mass (Lower limit)	1477kg / 29.1cwt	1714kg / 33.7cwt	1701kg / 33.5cwt
Maximum Technical Permissible Laden Mass (Upper limit)	1500kg / 29.5cwt	1750kg / 34.4cwt	1750kg / 34.4cwt
Total user Payload	126kg / 2.5cwt	156kg / 3.1cwt	156kg / 3.1cwt
Personal Effects	126kg / 2.5cwt	156kg / 3.1cwt	156kg / 3.1cwt
Options	0.0kg / 0.0cwt	0.0kg / 0.0cwt	0.0kg / 0.0cwt
Tyre Size	185 R14C 102 Q	195 / 70 R15C 104 R	195 / 70 R15C 104 R
Tyre pressure at Lower limit MTPLM	4.3 bar / 62 psi	4.5 bar / 65 psi	4.5 bar / 65 psi
Tyre pressure at Upper limit MTPLM	4.4 bar / 64 psi	4.5 bar / 65 psi	4.5 bar / 65 psi
Static Load on Coupling Head	100kg	100kg	100kg
Thermal Insulation Grade	THREE	THREE	THREE
Bed Sizes			
Front Double	200cm x 186cm / 6'7" x 6'1"	200cm x 158cm / 6'7" x 5'2"	200cm x 168cm / 6'7" x 5'6"
or Front Nearside Single and Front Offside Single	181cm x 67cm / 5'11" x 2'2"		
Rear Double		190cm x 133cm / 6'3" x 4'4"	
Side Single (offside)			172cm x 74cm / 5'8" x 2'5"
Side Single (nearside)			190cm x 73cm / 6'3" x 2'4"

Masses: The masses are calculated in accordance to EU regulation 1230 / 2012 and NCC code of practice 304.

The Mass in Running Order (MRO) comprises:

1. The mass of the empty caravan as supplied by Swift including loose items such as the hook-up cable, kit bag, entrance step, manuals etc.
2. 10kg allowance for LPG

The MRO is calculated with the fresh water tank, toilet flush tank and water heater empty. If you travel with water in the fresh water tank, toilet flush tank and the water heater the payload will reduce accordingly.

The personal effects is based on the number of berths and the length of the caravan and includes an allowance of 20kg for a leisure battery.

The Maximum Technical Laden Mass (MTPLM) is the maximum mass allowed when the caravan is fully laden.

WARNING: Under no circumstances should the MTPLM be exceeded

580
4
1
5.93m / 19'5"
2.28m / 7'6"
2.61m / 8'7"
1.95m / 6'5"
7.54m / 24'9"
10.30m / 33'10"
1530kg / 30.1cwt
1686kg / 33.2cwt
1750kg / 34.4cwt
156kg / 3.1cwt
156kg / 3.1cwt
0.0kg / 0.0cwt
195 / 70 R15C 104 R
4.5 bar / 65 psi
4.5 bar / 65 psi
100kg
THREE
200cm x 168cm / 6'7" x 5'6"
182cm x 133cm / 6'0" x 4'4"

Bed Sizes: Please note that the front double bed sizes quoted are for seating configurations without chest of drawers. The front double bed width for a layout with a chest of drawers fitted will be reduced by 0.4m (1'4") from that stated.

Awning sizes: Due to the varying awning designs and sizes the awning sizes given are approximate only. Specific awning sizes must be confirmed by your dealer or the awning manufacturer prior to purchase.

Est = Estimated weight or bed size

**The dimensions given are approximate due to slight variations in suspension ride heights, loading conditions and tyre pressures.

Customers should verify the actual dimensions of their touring caravan before committing to anything that could be impacted by these dimensions

Please note: Any dealer fit options will reduce the overall payload available to the user of the caravan.

If you require additional payload it is possible to upgrade the MTPLM to the upper limit. Please contact your caravan dealer for more information.

Elegance Specification

Elegance	835	845	850
Berths	4	4	4
Axles	2	2	2
Internal Length (bed box height)	6.36m / 20'10"	6.36m / 20'10"	6.36m / 20'10"
Overall Width*	2.45m / 8'0"	2.45m / 8'0"	2.45m / 8'0"
Overall Height (inc. TV Aerial)*	2.59m / 8'6"	2.59m / 8'6"	2.59m / 8'6"
Maximum Internal Headroom	1.95m / 6'5"	1.95m / 6'5"	1.95m / 6'5"
Overall Length*	7.98m / 26'2"	7.98m / 26'2"	7.98m / 26'2"
Awning A / A dimension	10.49m / 34'5"	10.49m / 34'5"	10.49m / 34'5"
Mass in Running Order (inc. tolerance)	1775kg / 34.9cwt	1740kg / 34.3cwt	1770kg / 34.8cwt
Maximum Technical Permissible Laden Mass (Lower limit)	1976kg / 38.9cwt	1941kg / 38.2cwt	1971kg / 38.8cwt
Maximum Technical Permissible Laden Mass (Upper limit)	2000kg / 39.4cwt	2000kg / 39.4cwt	2000kg / 39.4cwt
Total user Payload	201kg / 4.0cwt	201kg / 4.0cwt	201kg / 4.0cwt
Personal Effects	160kg / 3.1cwt	160kg / 3.1cwt	160kg / 3.1cwt
Options	41kg / 0.8cwt	41kg / 0.8cwt	41kg / 0.8cwt
Tyre Size	185 / 70 R14 88 T	185 / 70 R14 88 T	185 / 70 R14 88 T
Tyre pressure at Lower limit MTPLM	2.5 bar / 36 psi	2.4 bar / 35 psi	2.4 bar / 35 psi
Tyre pressure at Upper limit MTPLM	2.5 bar / 36 psi	2.5 bar / 36 psi	2.5 bar / 36 psi
Static Load on Coupling Head	100kg	100kg	100kg
Thermal Insulation Grade	THREE	THREE	THREE
Bed Sizes			
Front Double	218cm x 153cm / 7'2" x 5'0"	218cm x 153cm / 7'2" x 5'0"	194cm x 121cm / 6'4" x 4'0"
or Front Nearside Single	153cm x 70cm / 5'0" x 2'4"	153cm x 70cm / 5'0" x 2'4"	
and Front Offside Single	153cm x 70cm / 5'0" x 2'4"	153cm x 70cm / 5'0" x 2'4"	
Rear Double	184cm x 133cm / 6'0" x 4'4"	184cm x 133cm / 6'0" x 4'4"	189cm x 143cm / 6'2" x 4'8"

Masses: The masses are calculated in accordance to EU regulation 1230 / 2012 and NCC code of practice 304.

The Mass in Running Order (MRO) comprises:

1. The mass of the empty caravan as supplied by Swift including loose items such as the hook-up cable, kit bag, entrance step, manuals etc.
2. 10kg allowance for LPG

The MRO is calculated with the fresh water tank, toilet flush tank and water heater empty. If you travel with water in the fresh water tank, toilet flush tank and the water heater the payload will reduce accordingly.

The personal effects is based on the number of berths and the length of the caravan and includes an allowance of 20kg for a leisure battery.

The Maximum Technical Laden Mass (MTPLM) is the maximum mass allowed when the caravan is fully laden.

WARNING: Under no circumstances should the MTPLM be exceeded

Bed Sizes: Please note that the front double bed sizes quoted are for seating configurations without chest of drawers. The front double bed width for a layout with a chest of drawers fitted will be reduced by 0.4m (1'4") from that stated.

Awning sizes: Due to the varying awning designs and sizes the awning sizes given are approximate only. Specific awning sizes must be confirmed by your dealer or the awning manufacturer prior to purchase.

Est = Estimated weight or bed size

**The dimensions given are approximate due to slight variations in suspension ride heights, loading conditions and tyre pressures.

Customers should verify the actual dimensions of their touring caravan before committing to anything that could be impacted by these dimensions

Please note: Any dealer fit options will reduce the overall payload available to the user of the caravan.

If you require additional payload it is possible to upgrade the MTPLM to the upper limit. Please contact your caravan dealer for more information.

Wiring Diagrams - Road Lighting

Basecamp

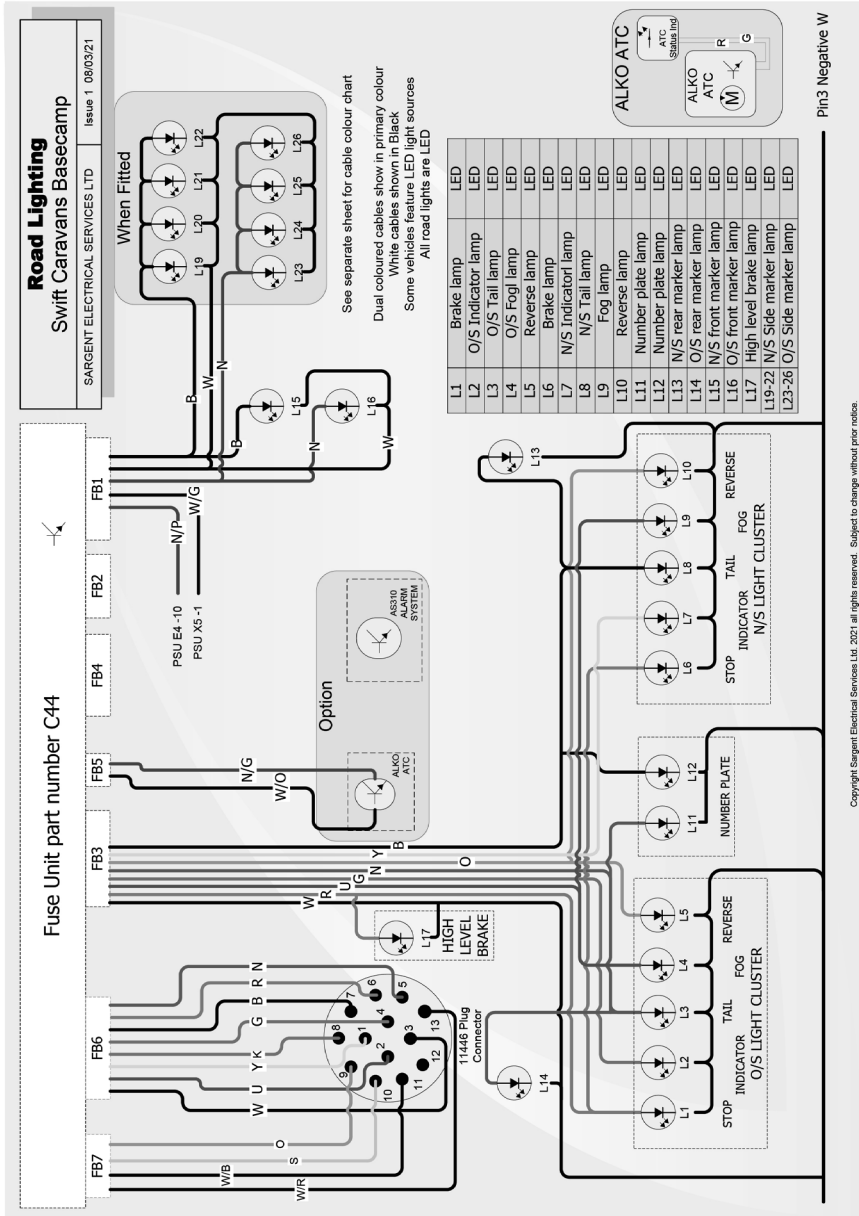

Wiring Diagrams - Road Lighting

Sprite, Sprite Super, Challenger, Challenger X, Conqueror and Elegance

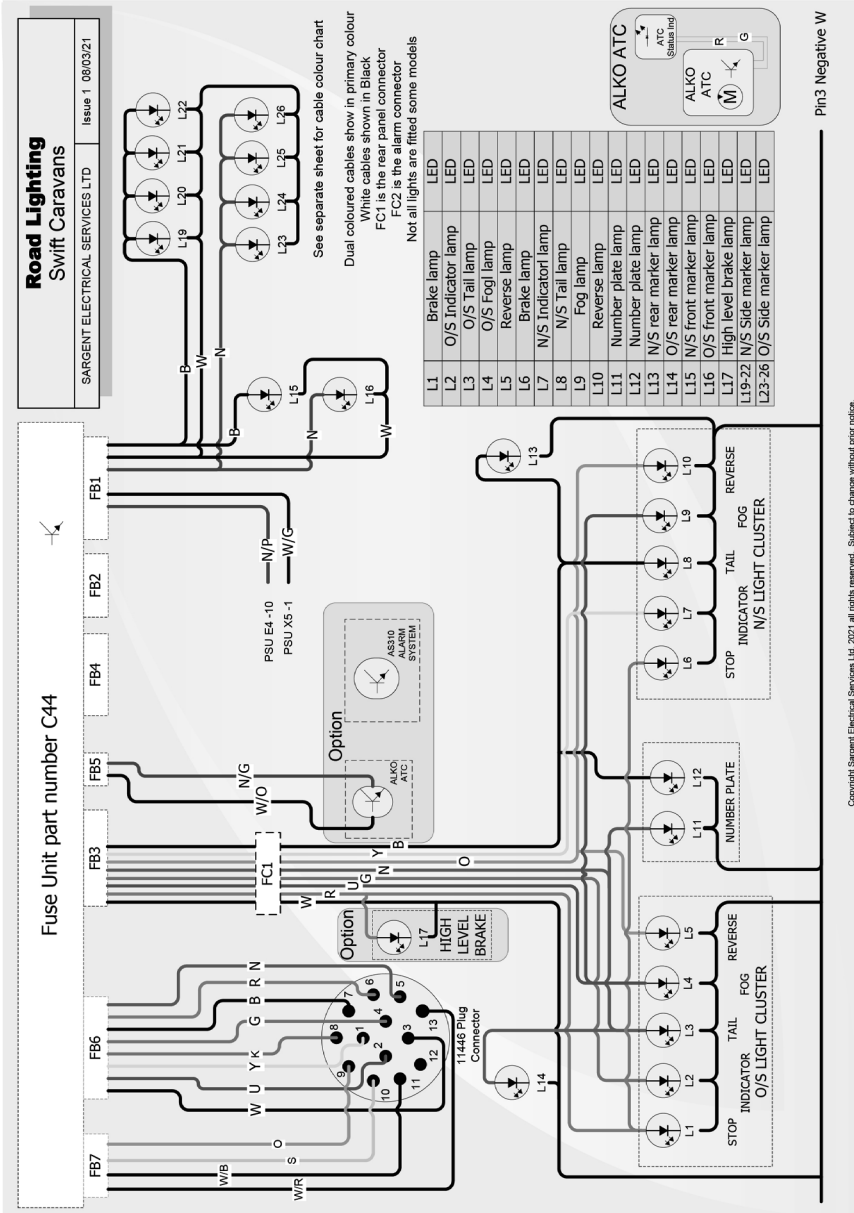

Wiring Diagrams - Consumer Circuits

Basecamp

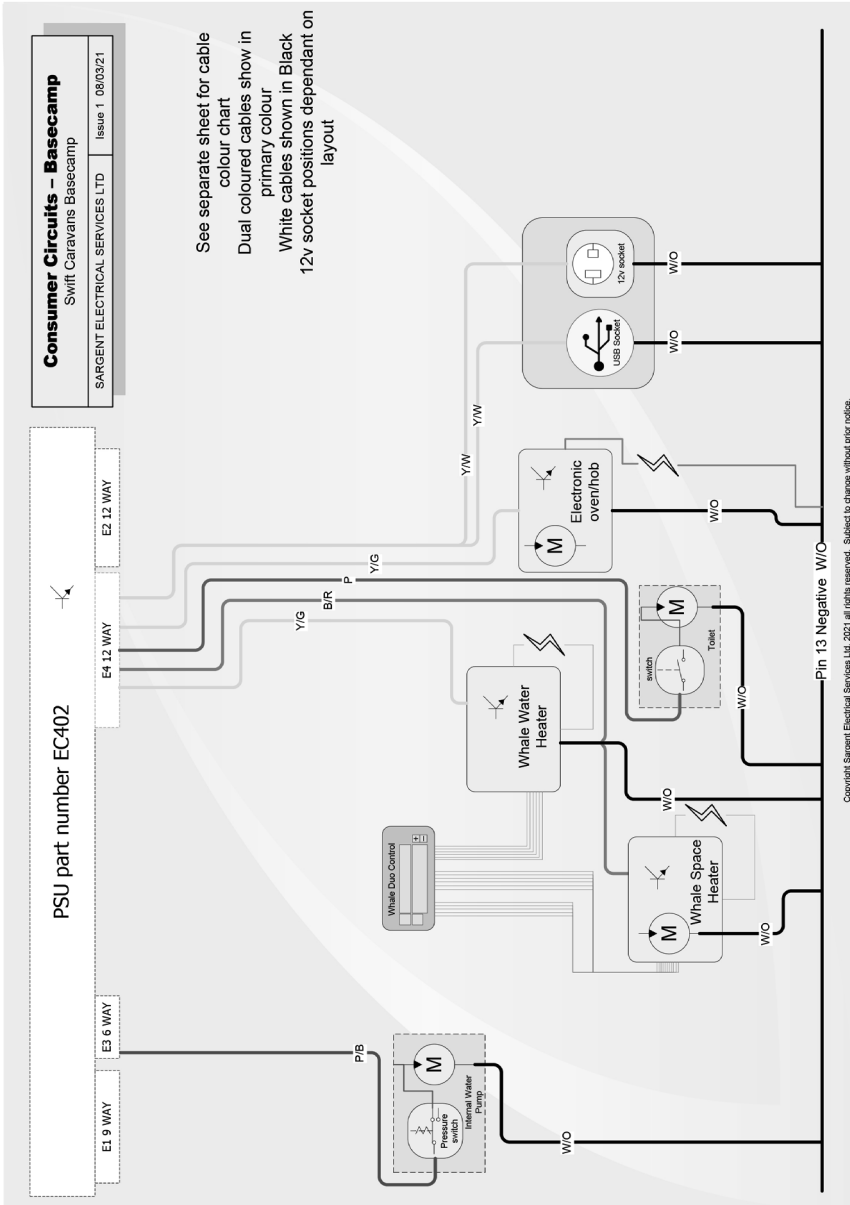

Wiring Diagrams - Consumer Circuits

Floor with Combi heating: Sprite and Sprite Super

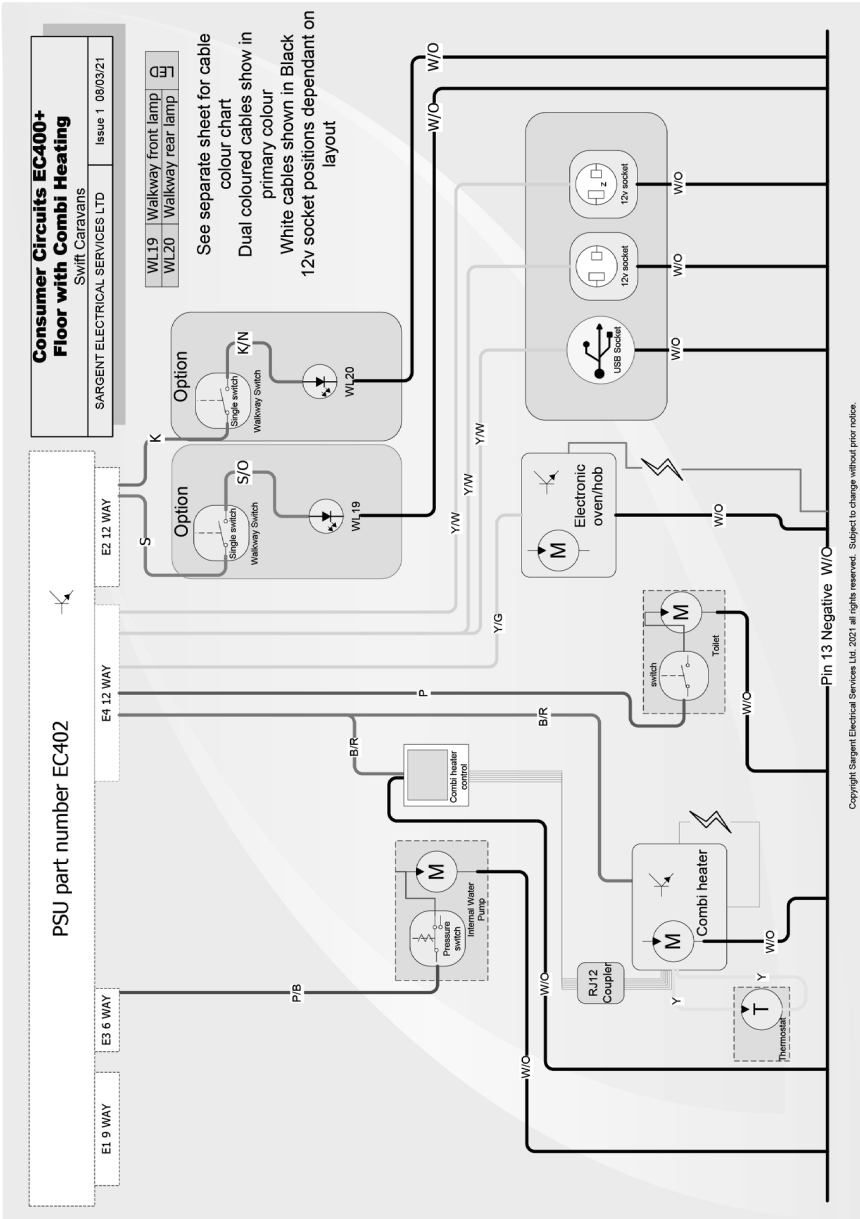

Copyright Sargent Electrical Services Ltd. 2021 all rights reserved. Subject to change without prior notice.

Wiring Diagrams - Consumer Circuits

Floor with Alde heating - Challenger and Challenger X

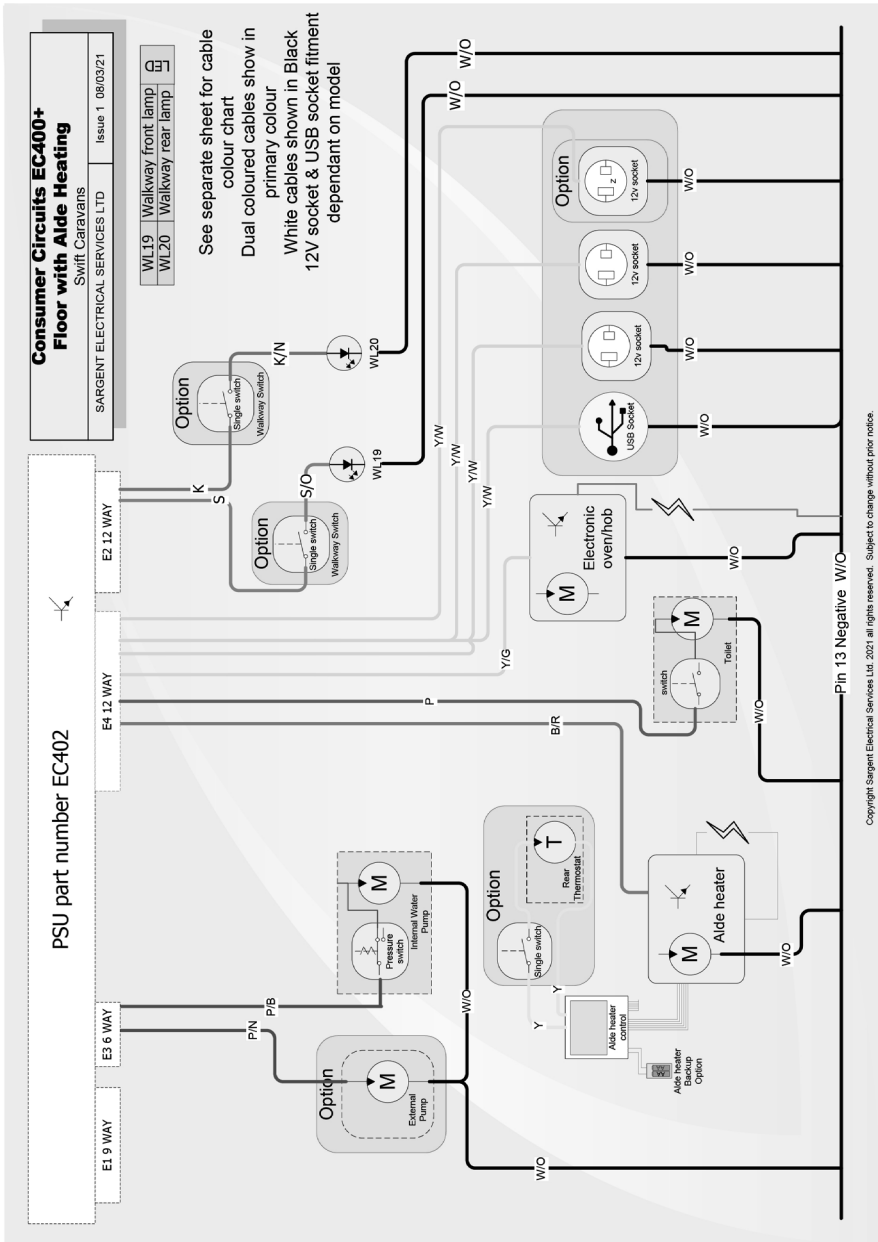

Wiring Diagrams - Consumer Circuits

Conqueror and Elegance

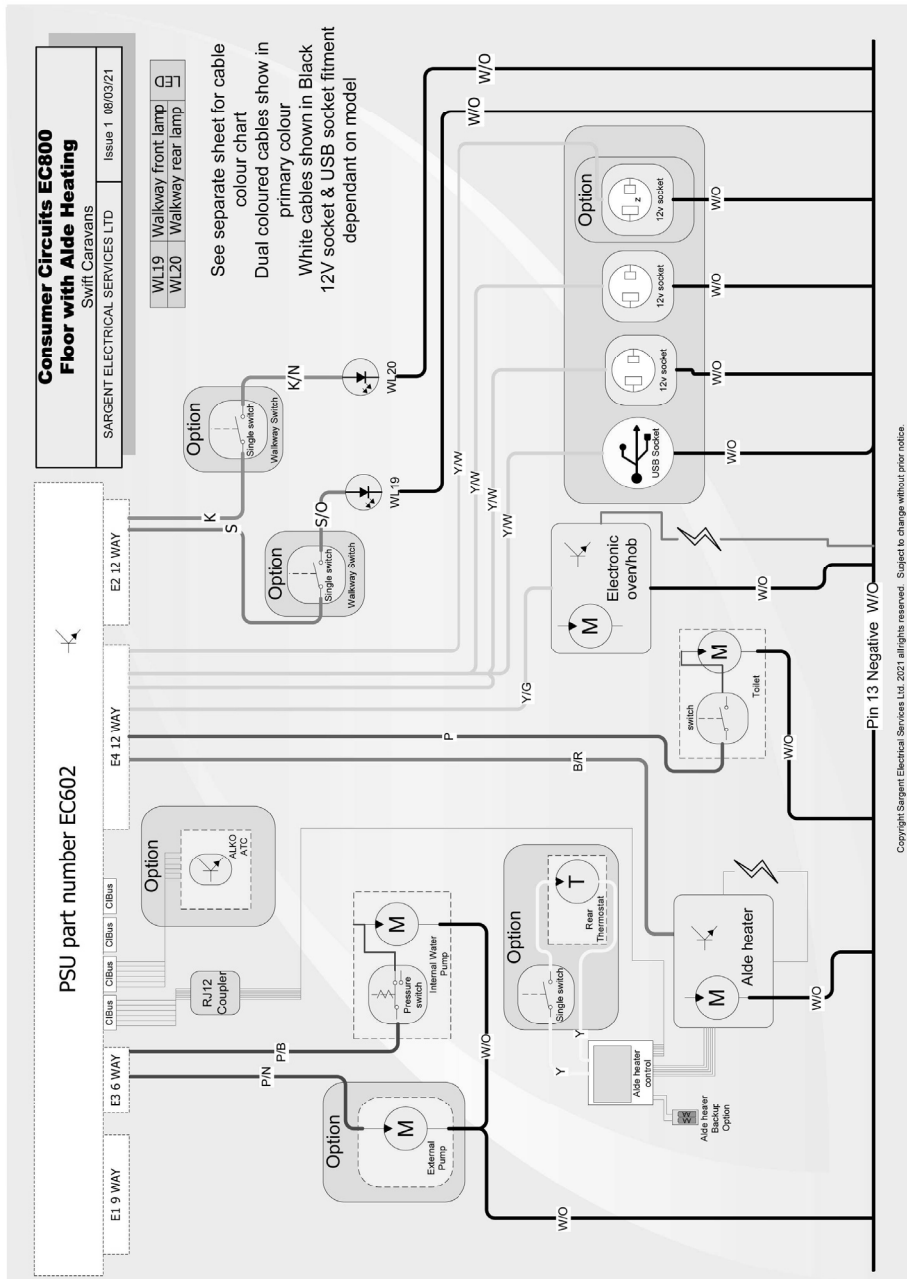

Wiring Diagrams - Consumer Circuits - Roof

Basecamp

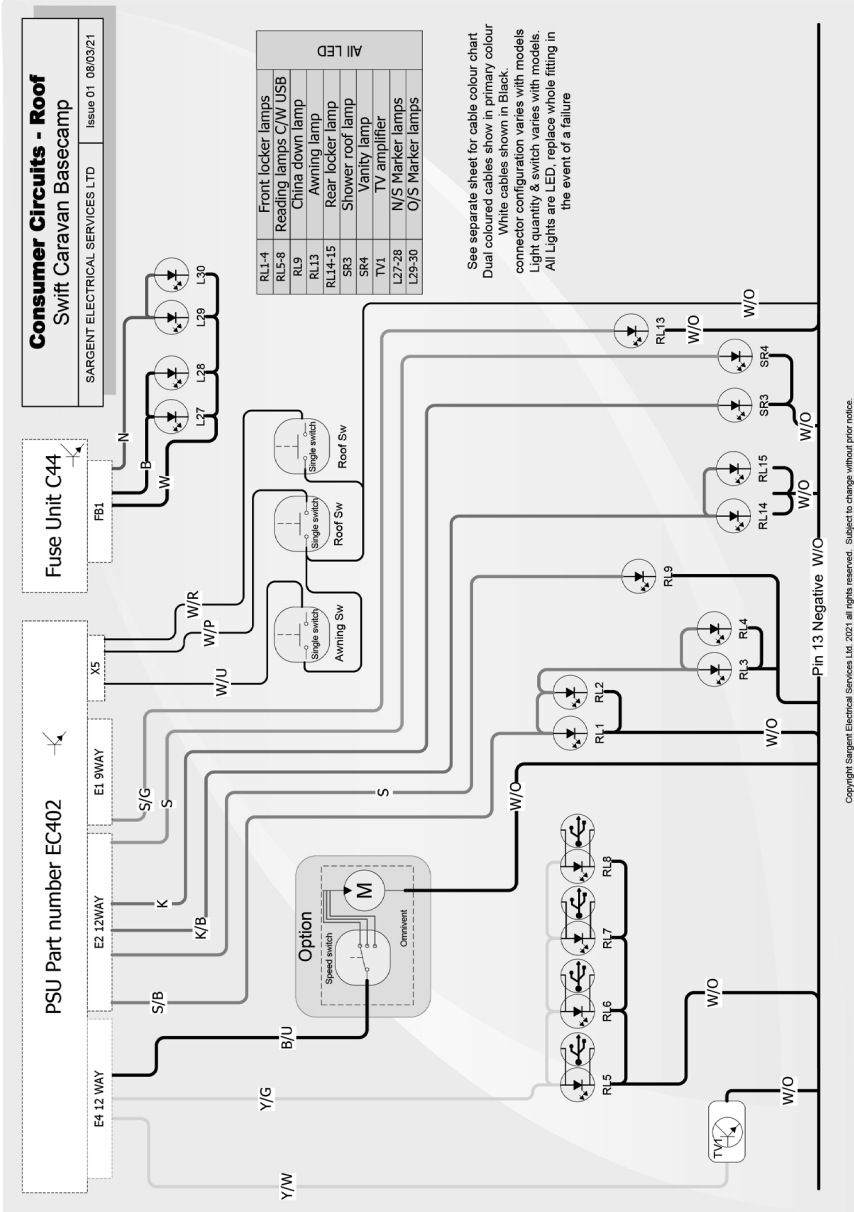

Wiring Diagrams - Consumer Circuits - Roof

Sprite, Sprite Super, Challenger and Challenger X

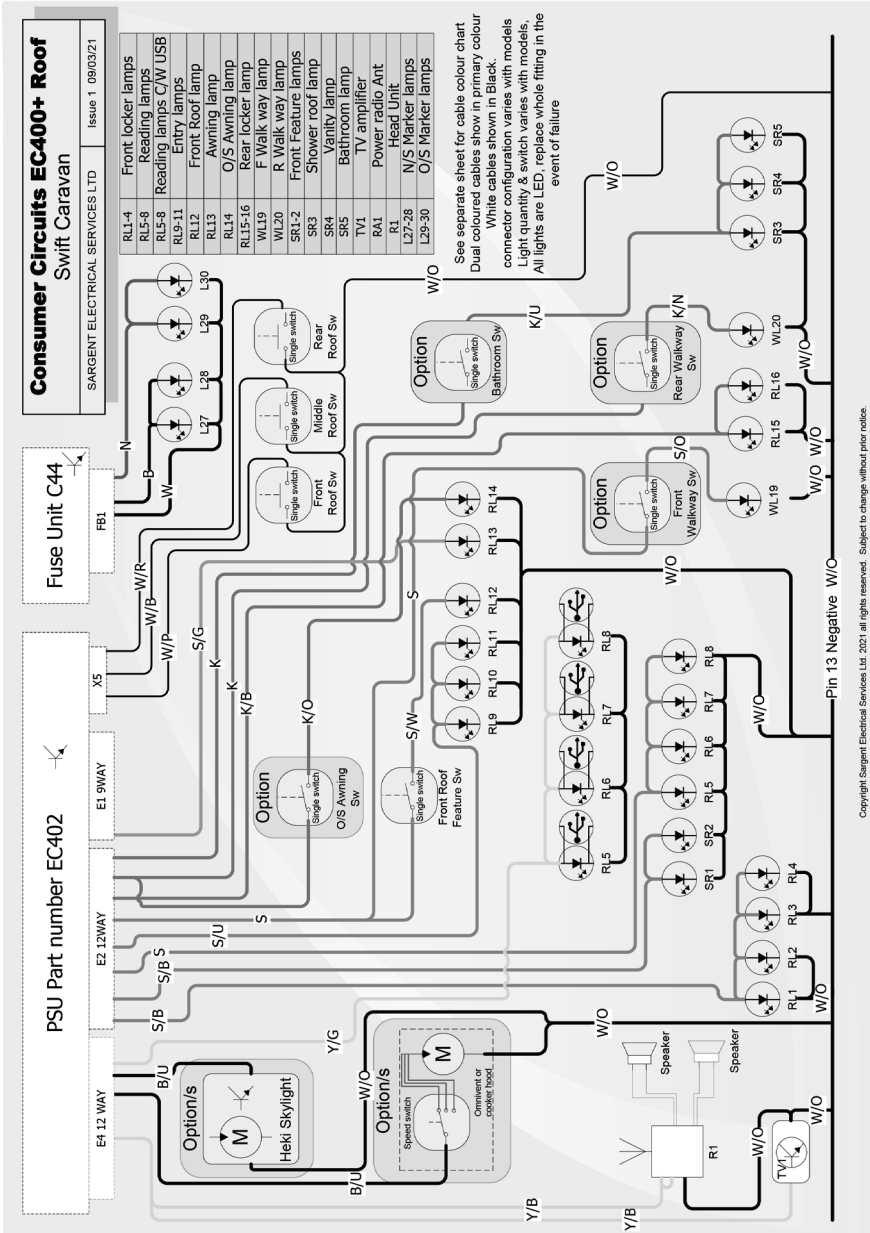

Wiring Diagrams - Consumer Circuits - Roof

Conqueror and Elegance

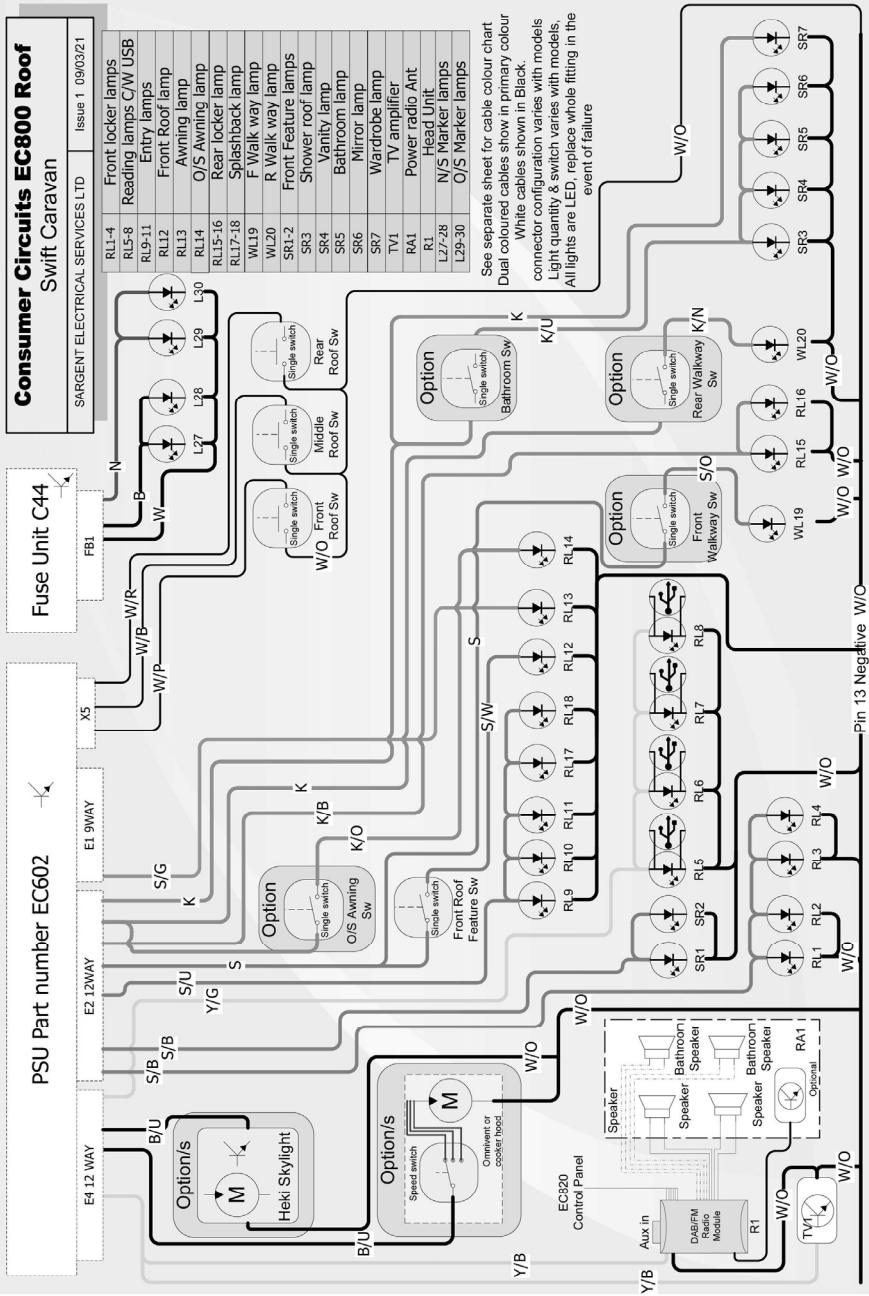

Copyright Sargent Electrical Services Ltd. 2021 all rights reserved. Subject to change without prior notice.

Wiring Diagrams - Power Circuits

Basecamp

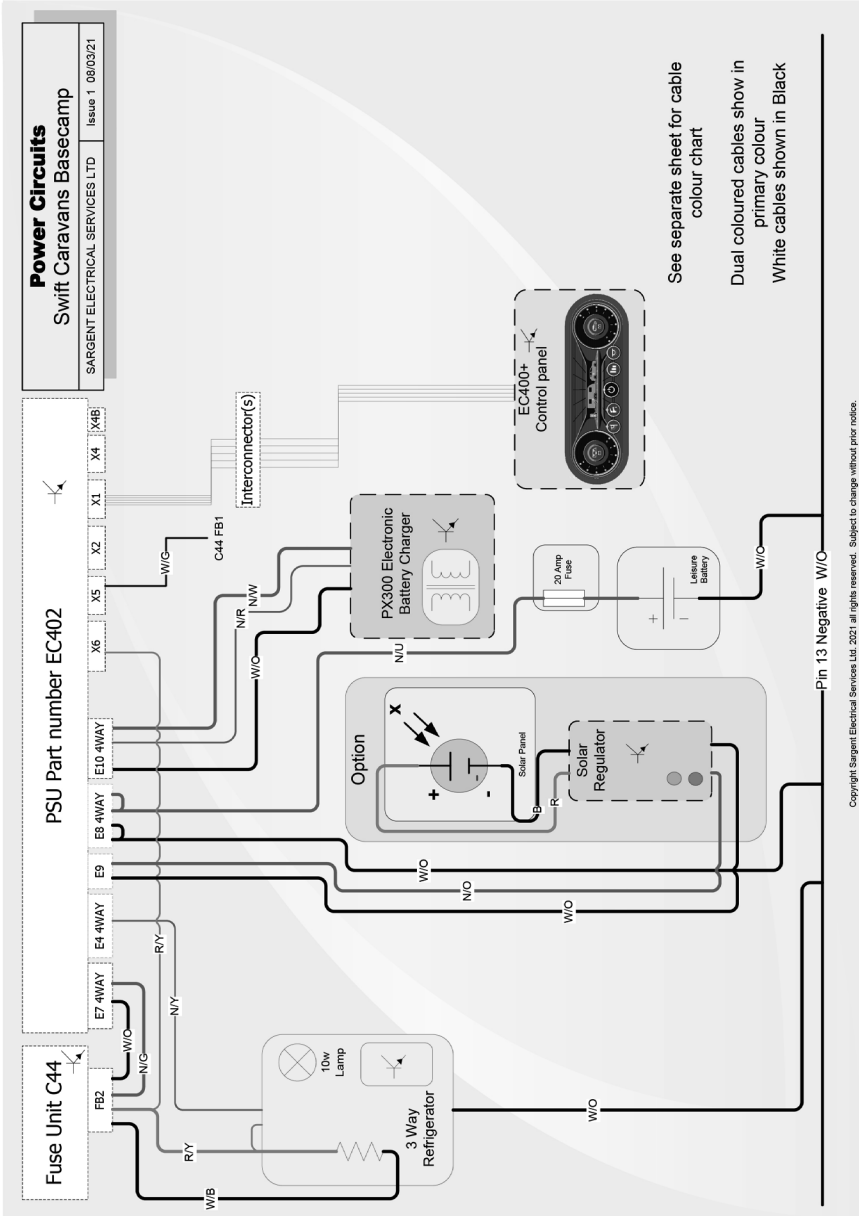

Wiring Diagrams - Power Circuits

Sprite, Sprite Super, Challenger and Challenger X

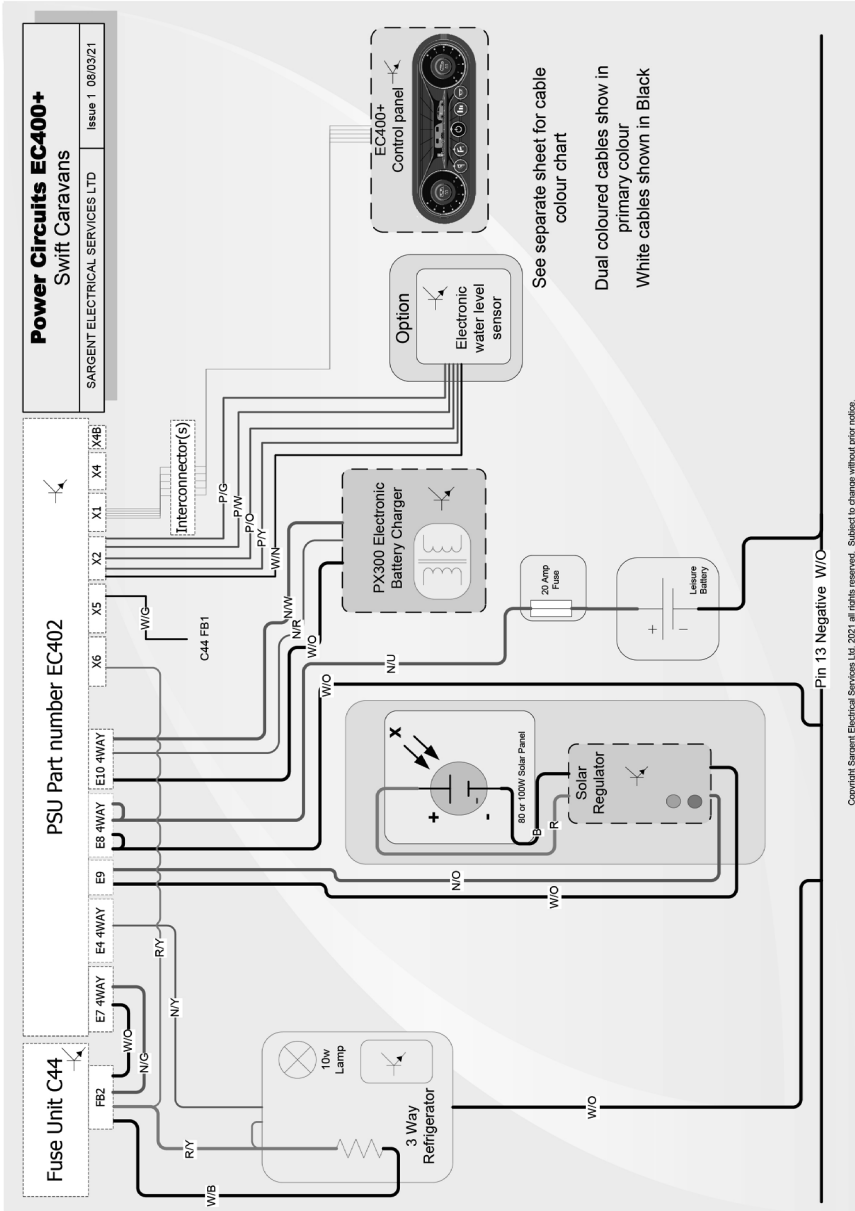

Wiring Diagrams - Power Circuits

Conqueror and Elegance

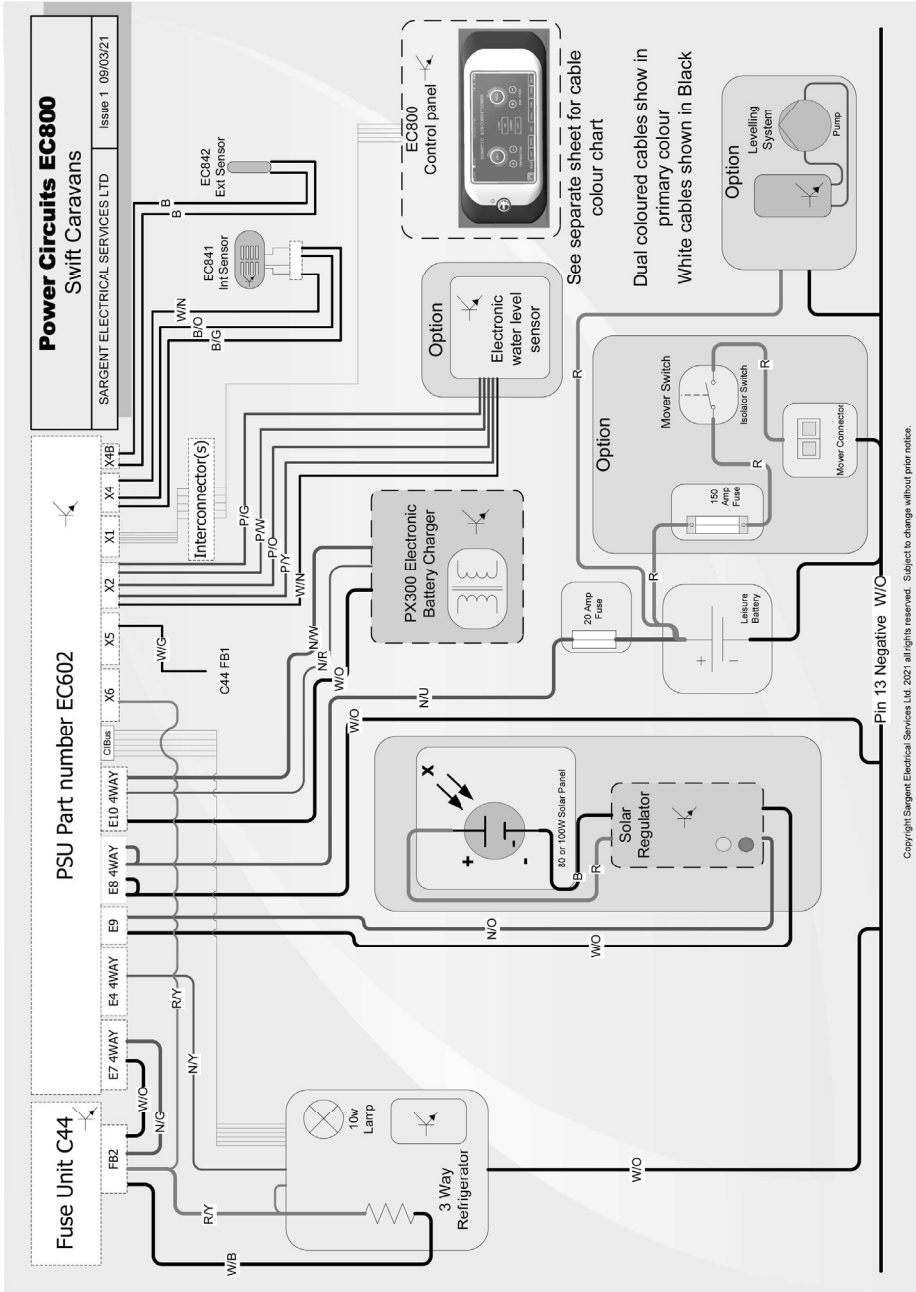

Copyright Sargent Electrical Services Ltd. 2021. All rights reserved. Subject to change without prior notice.

Wiring Diagrams - 230V Circuits

Basecamp

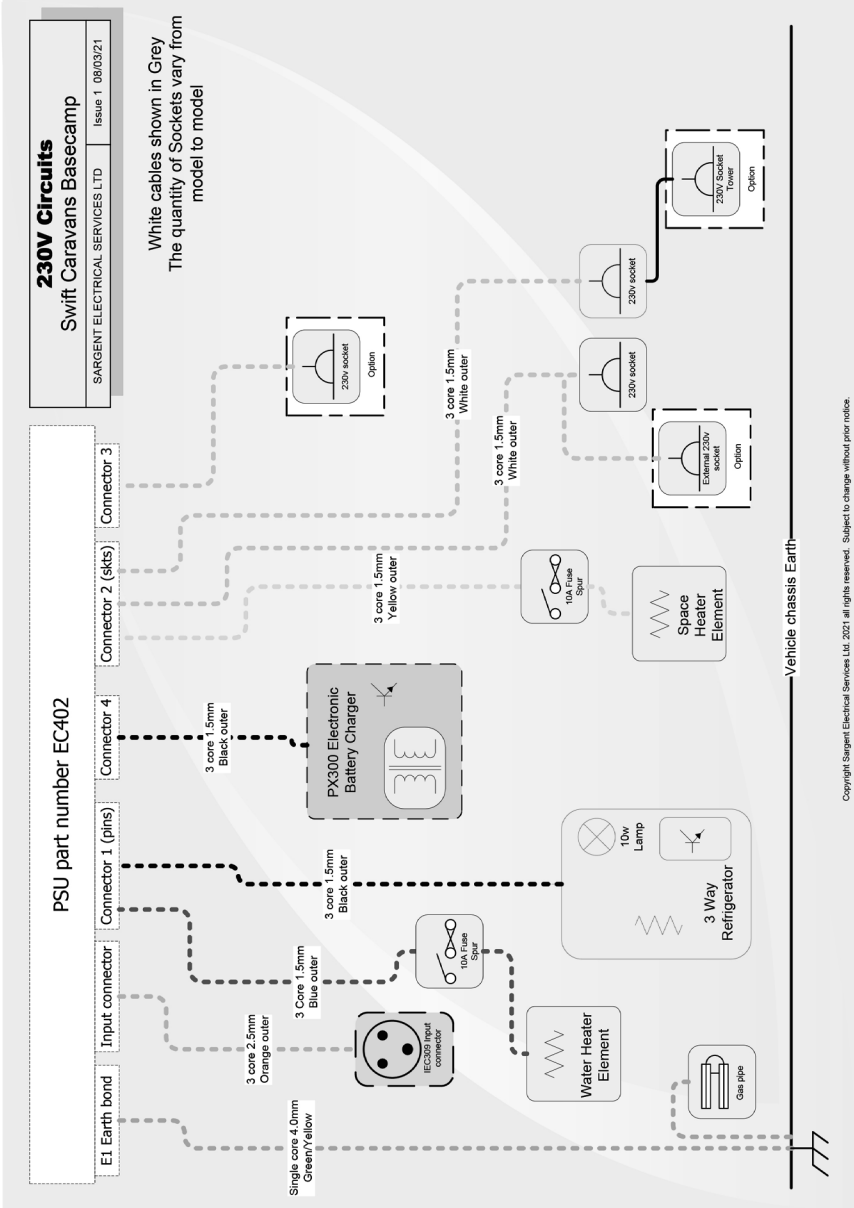

Wiring Diagrams - 230V Circuits

Sprite, Sprite Super, Challenger, Challenger X, Conqueror and Elegance

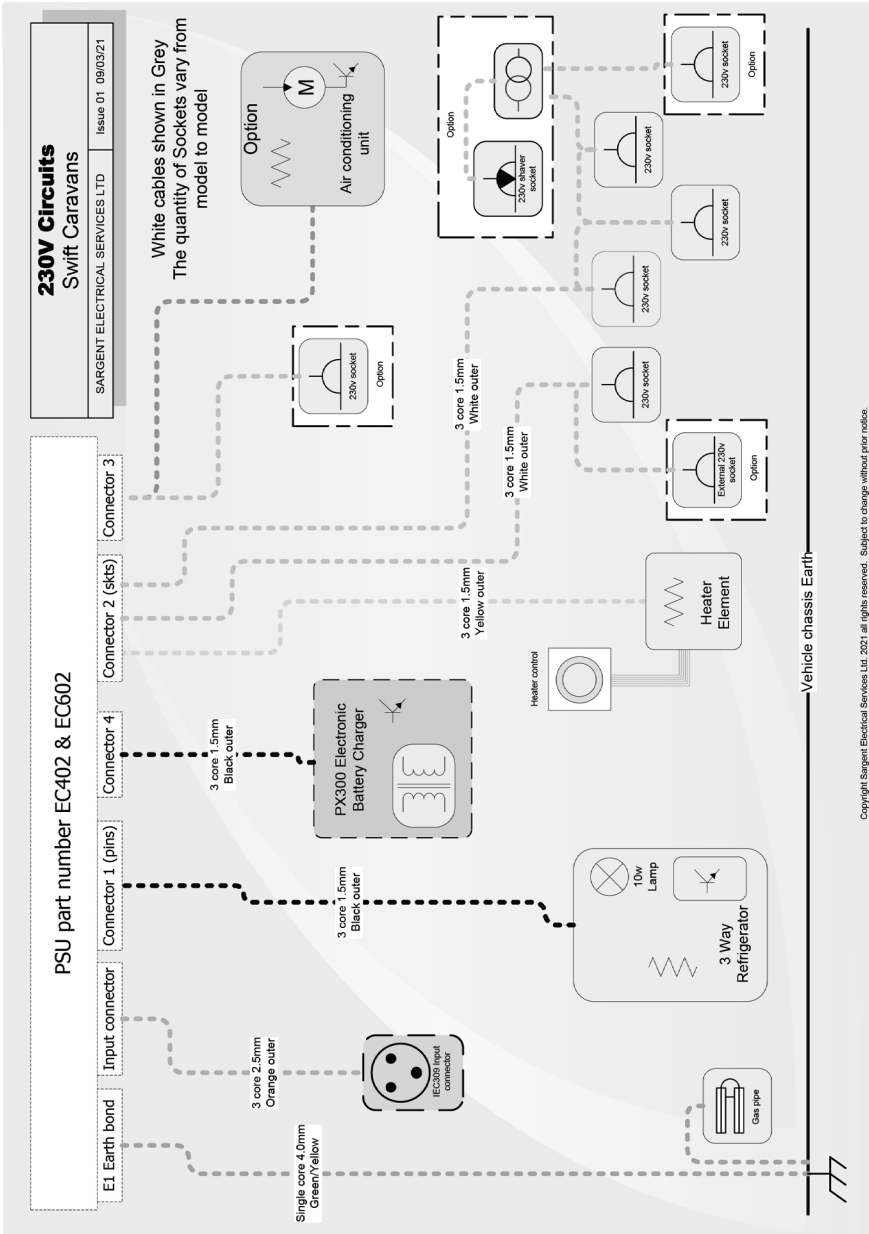

Wiring Diagrams - 13 Pin Socket

ISO 11446 Circuits

Swift Group Caravans (where applicable)

SARGENT ELECTRICAL SERVICES LTD

Issue 01 06/03/21

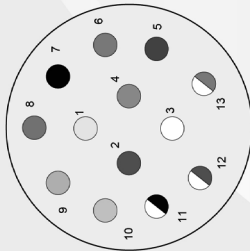

11446 Plug Connector viewed from cable entry on plug



It is possible to get adaptors that convert two sockets on the towbar to a single 13 pin ISO socket, and vice versa.

Connection lead from 12N 7 pin socket plus 12S 7 pin socket to 13pin Euro Socket. (Converts a vehicle with two 7 pin sockets to a caravan with a 13 pin plug)

Please be aware that some car and adaptor manufacturers don't provide the fridge power connections

Pin No	Core Colour	Core Size	Function
1	Yellow	1.5	Left Hand Indicator Light
2	Blue	1.5	Rear Fog Warning Light(s)
3	White	2.5	Earth for pins 1 - 8
4	Green	1.5	Right Hand Indicator Light
5	Brown	1.5	Right Hand Tail Light
6	Red	1.5	Brake Lights
7	Black	1.5	Left Hand Tail Light
8	Pink	1.5	Reverse Light(s)
9	Orange	2.5	Car +ve
10	Slate (Grey)	2.5	Fridge +ve
11	White/Black	2.5	Earth for pin 10
12	White/Blue	1.5	Not Yet Allocated
13	White/Red	2.5	Earth for pin 9

Wiring Diagrams - Cable Colour Chart

Example



Y/U

Yellow cable with Blue stripe

Cable Colour Chart

Swift range

SARGENT ELECTRICAL SERVICES LTD Issue 1 09/03/21

12V Cable Colours

B	BLACK
N	BROWN
R	RED
O	ORANGE
Y	YELLOW
G	GREEN
U	BLUE
P	PURPLE
S	SLATE GREY
W	WHITE
K	PINK

230V Cable Colours

B	BLACK
N	BROWN
W	WHITE
O	ORANGE
Y	YELLOW
G	GREEN
U	BLUE

Bulb Replacement

ROAD LIGHT BULB ACCESS

REAR LIGHT CLUSTERS (CONTAINING INDICATOR, TAIL / STOP, REVERSE AND FOG LAMPS):

- These multi-function lights are LED and have no user serviceable parts inside.
- Replacement clusters can be fitted in the following way:
- Remove three screws visible around the perimeter of the cluster
- Pull the cluster away from the rear panel of the tourer, taking care to not put excessive strain on the electrical connections behind the lamp
- Unplug the electrical connection from the rear of the lamp, by releasing the tab and lifting the connector upwards relative to the cluster
- Plug the connector back into the replacement lamp, position the lamp into the recess and replace the three fixing screws.

FRONT LOW LEVEL MARKER / POSITION LAMPS (CLEAR LENSE)

- These lamps are LED and have no user serviceable parts inside.
- Replacements should be undertaken by your dealer, as the lamps are sealed onto the mounting panel.

HIGH LEVEL BRAKE LAMP

- This lamp is single piece and has no user serviceable parts inside.
- Replacements should be undertaken by your dealer, as the lamps are sealed onto the mounting panel.

NUMBER PLATE LAMPS

- These lamps are single piece and have no user serviceable parts inside.
- Replacements should be undertaken by your dealer, as the lamps are sealed onto the mounting panel.

SIDE MARKER / POSITION LAMPS (AMBER LENSE)

- These lamps are LED and have no user serviceable parts inside.
- Replacements should be undertaken by your dealer, as the lamps are sealed onto the mounting panel.

UPPER SIDE MARKER / POSITION LAMPS (RED AND WHITE LENSE)

- These lamps are LED and have no user serviceable parts inside.
- Replacement should be undertaken by your dealer, as the lamp is sealed onto the mounting panel.



Dealer Special specifications based on Sprite

Based on Sprite	Compact	Alpine 2	Alpine 4	Major 4 SB
Dealer				
KIMBERLEY	ICON COMPACT	ICON 2	ICON 4	ICON T4
WANDAHOME	HARMONY	AMBASSADOR	ENVOY	DIPLOMAT
COUPLAND	FINESSE 400	FINESSE 480	FINESSE 500	FINESSE 580
LOWDHAM	FREESTYLE COMPACT	FREESTYLE S2	FREESTYLE S4	FREESTYLE S4SB
PRESTON	KUDOS 350	KUDOS 440	KUDOS 470	KUDOS 530SB
BROADLANE	FAIRWAY COMPACT	FAIRWAY 460	FAIRWAY 470	FAIRWAY 580
GRANTHAM	SIENA COMPACT	SIENA 2	SIENA 4	SIENA 4SB
3A's	CHARISMA 360		CHARISMA 470	CHARISMA 580
SUSSEX	ASHURST COMPACT	CHILGROVE SPORT	GOODWOOD SPORT	FINDON SPORT
YC LEISURE	EXCLUSIVE COMPACT	EXCLUSIVE 2	EXCLUSIVE 4	EXCLUSIVE 4SB
LEISURE SALES	MARBURY COMPACT	MARBURY	DARESBURY	ASTBURY
SWINDON	VOGUE COMPACT	VOGUE 480	VOGUE 510FB	VOGUE 580SB
DUNCANS			BEN MORE	BEN NEVIS
WHITE ARCHES	LOWICK	WOODFORD	HARTWELL	TWYWELL
GLOSSOP	CELEBRATE IONA	CELEBRATE A2	CELEBRATE A4	CELEBRATE 4SB
TORKSEY	AVENTURAC2	AVENTURAA2	AVENTURAA4	AVENTURA M4SB
KIRKALDY				EUROPA 580
MG CARAVANS	ACCORD 380	ACCORD 480	ACCORD 510	ACCORD 580
TAMAR	MAYFLOWER 400	MAYFLOWER 480		MAYFLOWER 580
ROBINSONS	SUNRISE COMPACT	SUNRISE 480	SUNRISE 510	SUNRISE 580
TEESIDE	CONTINENTAL COMPACT	CONTINENTAL 480	CONTINENTAL 510	CONTINENTAL 580
SPINNEY	SPINNEY COMPACT VOGUE	SPINNEY ALPINE 2	SPINNEY ALPINE 4	SPINNEY MAJOR 4 SB
Berths	2	2	4	4
Axles	1	1	1	1
Internal Length (bed box height)	3.66m / 12'0"	4.34m / 14'3"	4.74m / 15'7"	5.83m / 19'2"
Overall Width**	2.03m / 6'8"	2.25m / 7'5"	2.25m / 7'5"	2.25m / 7'5"
Overall Height (inc. TV Aerial)**	2.59m / 8'6"	2.59m / 8'6"	2.59m / 8'6"	2.59m / 8'6"
Maximum Internal Headroom	1.95m / 6'5"	1.95m / 6'5"	1.95m / 6'5"	1.95m / 6'5"
Overall Length**	5.37m / 17'7"	6.05m / 19'10"	6.45m / 21'2"	7.54m / 24'9"
Awning A / A dimension	7.95m / 26'1"	8.59m / 28'2"	8.99m / 29'6"	10.08m / 33'1"
Mass in Running Order (inc. tolerance)	995.0kg / 19.6cwt	1112kg / 21.9cwt	1154kg / 22.7cwt	1306kg / 25.7cwt
Maximum Technical Permissible Laden Mass (Lower limit)	1109.0kg / 21.8cwt	1233kg / 24.3cwt	1300kg / 25.6cwt	1462kg / 28.8cwt
Maximum Technical Permissible Laden Mass (Upper limit)	1200.0kg / 23.6cwt	1250kg / 24.6cwt	1300kg / 25.6cwt	1500kg / 29.5cwt
Total user Payload	114kg / 2.2cwt	121kg / 2.4cwt	146kg / 2.9cwt	156kg / 3.1cwt
Personal Effects	114kg / 2.2cwt	121kg / 2.4cwt	145kg / 2.9cwt	156kg / 3.1cwt
Options	0kg / 0.0cwt	0kg / 0cwt	0kg / 0cwt	0kg / 0cwt
Tyre Size	185 R14C 102 Q	185 R14C 102 Q	185 R14C 102 Q	185 R14C 102 Q
Tyre pressure at Lower limit MTPLM	3.4bar / 49psi	3.4 bar / 49 psi	3.7 bar / 54 psi	4.2 bar / 61 psi
Tyre pressure at Upper limit MTPLM	3.4bar / 49psi	3.5 bar / 51 psi	3.7 bar / 54 psi	4.4 bar / 64 psi
Static Load on Coupling Head	100kg	100kg	100kg	100kg
Thermal Insulation Grade	THREE	THREE	THREE	THREE
Bed Sizes				
Front Double	182cm x 180cm / 6'0" x 5'11"	202cm x 180cm / 6'8" x 5'11"	202cm x 128cm / 6'8" x 4'2"	202cm x 159cm / 6'8" x 5'3"
or Front Nearside Single	180cm x 65cm / 5'11" x 2'2"	190cm x 72cm / 6'3" x 2'4"		159cm x 72cm / 5'3" x 2'4"
and Front Offside Single	180cm x 65cm / 5'11" x 2'2"	180cm x 72cm / 5'11" x 2'4"		159cm x 72cm / 5'3" x 2'4"
Rear Double			189cm x 132cm / 6'2" x 4'4"	185cm x 133cm / 6'1" x 4'4"
Side Single (offside)				
Side Single (nearside)				
Side Bunk (offside)				
Side Bunk (nearside)				
Side Fixed Lower Bunk				
Side Fixed Upper Bunk				

Masses: The masses are calculated in accordance to EU regulation 1230 / 2012 and NCC code of practice 304.

The Mass in Running Order (MRO) comprises:

1. The mass of the empty caravan as supplied by Swift including loose items such as the hook-up cable, kit bag, entrance step, manuals etc.
2. 10kg allowance for LPG

The MRO is calculated with the fresh water tank, toilet flush tank and water heater empty. If you travel with water in the fresh water tank, toilet flush tank and the water heater the payload will reduce accordingly.

The personal effects is based on the number of berths and the length of the caravan and includes an allowance of 20kg for a leisure battery.

The Maximum Technical Laden Mass (MTPLM) is the maximum mass allowed when the caravan is fully laden.

WARNING: Under no circumstances should the MTPLM be exceeded

Major 4 EB	Major 6 TD	Quattro EW	Quattro FB
ICON I4	ICON 6		
GLOBETROTTER	VISCOUNT	PIONEER	PRESTIGE
FINESSE 560	FINESSE 590		
FREESTYLE S4EB	FREESTYLE S6TD		
KUDOS 530EB			KUDOS 630FB
FAIRWAY 560	FAIRWAY 590		
SIENA 4 EB	SIENA 6TD	SIENA 6EW	SIENA 6FB
CHARISMA 560	CHARISMA 590	CHARISMA 630	CHARISMA 625
AMBERLEY SPORT	WASHINGTON SPORT		
EXCLUSIVE 4EB	EXCLUSIVE 6TD	EXCLUSIVE EW	EXCLUSIVE FB
HENBURY	PRESTBURY	WRENBURY L	
VOGUE 560EB	VOGUE 590		
CAIRNGORM	CULMOR		
ROCKINGHAM	COTTINGHAM		
CELEBRATE 4EB	CELEBRATE 6TD	CELEBRATE QEW	CELEBRATE QFB
AVENTURA M4EB	AVENTURA M6TD	AVENTURA Q6EW	AVENTURA Q6FB
EUROPA 560	EUROPA 590		
ACCORD 560	ACCORD 590		
MAYFLOWER 560	MAYFLOWER 590		
SUNRISE 560	SUNRISE 590		SUNRISE 620
CONTINENTAL 560	CONTINENTAL 590	CONTINENTAL 630	CONTINENTAL 620
SPINNEY MAJOR 4 EB	SPINNEY MAJOR 6TD	SPINNEY QUATTRO EW	
4	6	6	6
1	1	2	2
5.83m / 19'2"	5.83m / 19'2"	6.27m / 20'7"	6.27m / 20'7"
2.25m / 7'5"	2.25m / 7'5"	2.25m / 7'5"	2.25m / 7'5"
2.59m / 8'6"	2.59m / 8'6"	2.59m / 8'6"	2.59m / 8'6"
1.95m / 6'5"	1.95m / 6'5"	1.95m / 6'5"	1.95m / 6'5"
7.54m / 24'9"	7.54m / 24'9"	7.98m / 26'2"	7.98m / 26'2"
10.08m / 33'1"	10.08m / 33'1"	10.52m / 34'6"	10.52m / 34'6"
1344kg / 26.5cwt	1374kg / 27.0cwt	1460kg / 28.7cwt	1470kg / 28.9cwt
1500kg / 29.5cwt	1550kg / 30.5cwt	1640kg / 32.3cwt	1650kg / 32.5cwt
1500kg / 29.5cwt	1550kg / 30.5cwt	1800kg / 35.4cwt	1800kg / 35.4cwt
156kg / 3.1cwt	176kg / 3.5cwt	180kg / 3.5cwt	180kg / 3.5cwt
156kg / 3.1cwt	176kg / 3.5cwt	180kg / 3.5cwt	180kg / 3.5cwt
0kg / 0cwt	0kg / 0cwt	0kg / 0cwt	0kg / 0cwt
185 R14C 102Q	185 R14C 102Q	185 / 70 R14 88T	185 / 70 R14 88T
4.4 bar / 64 psi	4.5 bar / 65 psi	2.0 bar / 29 psi	2.0 bar / 29 psi
4.4 bar / 64 psi	4.5 bar / 65 psi	2.2 bar / 32 psi	2.2 bar / 32 psi
100kg	100kg	100kg	100kg
THREE	THREE	THREE	THREE
202cm x 159cm / 6'8" x 5'3"	202cm x 180cm / 6'8" x 5'11"	206cm x 134cm / 6'9" x 4'5"	202cm x 180cm / 6'8" x 5'11"
159cm x 72cm / 5'3" x 2'4"	190cm x 72cm / 6'3" x 2'4"		180cm x 72cm / 5'11" x 2'4"
159cm x 72cm / 5'3" x 2'4"	180cm x 72cm / 5'11" x 2'4"		190cm x 72cm / 6'3" x 2'4"
190cm x 133cm / 6'3" x 4'4"		194cm x 132cm / 6'4" x 4'4"	192cm x 132cm / 6'4" x 4'4"
		180cm x 62cm / 5'11" x 2'0"	180cm x 62cm / 5'11" x 2'0"
	180cm x 67cm / 5'11" x 2'2"		
		176cm x 59cm / 5'9" x 1'11"	176cm x 59cm / 5'9" x 1'11"
	176cm x 59cm / 5'9" x 1'11"		
	183cm x 57cm / 6'0" x 1'10"		
	183cm x 57cm / 6'0" x 1'10"		

Bed Sizes: Please note that the front double bed sizes quoted are for seating configurations without chest of drawers. The front double bed width for a layout with a chest of drawers fitted will be reduced by 0.4m (1'4") from that stated.

Awning sizes: Due to the varying awning designs and sizes the awning sizes given are approximate only. Specific awning sizes must be confirmed by your dealer or the awning manufacturer prior to purchase.

Est = Estimated weight or bed size

**The dimensions given are approximate due to slight variations in suspension ride heights, loading conditions and tyre pressures.

Customers should verify the actual dimensions of their touring caravan before committing to anything that could be impacted by these dimensions

Please note: Any dealer fit options will reduce the overall payload available to the user of the caravan.

If you require additional payload it is possible to upgrade the MTPLM to the upper limit. Please contact your caravan dealer for more information.

Dealer Special specifications based on Sprite Super

Based on	Sprite Super Major 4SB	Sprite Super Quattro FB	Sprite Super Quattro DB
Dealer			
KIMBERLEY	ICON T4/8	ICON FB/8	ICON DB/8
WANDAHOME	DAYSTAR	NIGHTSTAR	SUPERSTAR
COUPLANDS	FINESSE 880	FINESSE 825	FINESSE 865
LOWDHAM	FREESTYLE SUPER 5B		FREESTYLE SUPER DB
PRESTON	KUDOS 8305B	KUDOS 830FB	KUDOS 830DB
GRANTHAM	SIENA SUPER 4SB	SIENA SUPER 6FB	SIENA SUPER 6DB
3A'S	CHARISMA EXCEL 840	CHARISMA EXCEL 825	CHARISMA EXCEL 815
YC LEISURE	EXCLUSIVE 4SB SUPER	EXCLUSIVE 6FB SUPER	EXCLUSIVE 6DB SUPER
LEISURE SALES		WRENBURY FBW	
SWINDON	VOGUE 580 GRANDE		
DUNCANS	CUILLIN	BEN VORLICH	
WHITE ARCHES	TWYWELL X	CALDECOTT	HARRINGWORTH
GLOSSOP	CELEBRATE SUPER 4SB	CELEBRATE SUPER QFB	CELEBRATE SUPER QDB
TORKSEY	AVENTURA SM45B	AVENTURA SQ6FB	AVENTURA SQ6DB
KIRKALDY	EUROPA 880	EUROPA 840	EUROPA 866
MG CARAVANS	ACCORD 880	ACCORD 820	ACCORD 825
TAMAR		MAYFLOWER 830	
ROBINSONS	SUNRISE 880		SUNRISE 820
TEESIDE	CONTINENTAL 880	CONTINENTAL 830	CONTINENTAL 825
SPINNEY	SPINNEY SUPER MAJOR 4SB		SPINNEY SUPER QUATTRO DB
Berths	4	6	6
Axles	1	2	2
Internal Length (bed box height)	5.83m / 19' 2"	6.27m / 20'7"	6.27m / 20'7"
Overall Width**	2.46m / 8'1"	2.46m / 8'1"	2.46m / 8'1"
Overall Height (inc. TV Aerial)**	2.61m / 8'7"	2.59m / 8'6"	2.59m / 8'6"
Maximum Internal Headroom	1.95m / 6'5"	1.95m / 6'5"	1.95m / 6'5"
Overall Length**	7.54m / 24'9"	7.98m / 26'2"	7.98m / 26'2"
Awning A / A dimension	10.20m / 33'6"	10.56m / 34'8"	10.56m / 34'8"
Mass in Running Order (inc. Tolerance)	1410kg / 27.8cwt	1545kg / 30.4cwt	1551kg / 30.5cwt
Maximum Technical Permissible Laden Mass (Lower limit)	1566kg / 30.8cwt	1725kg / 34.0cwt	1731kg / 34.1cwt
Maximum Technical Permissible Laden Mass (Upper limit)	1650kg / 32.5cwt	1800kg / 35.4cwt	1800kg / 35.4cwt
Total user Payload	156kg / 3.1cwt	180kg / 3.5cwt	180kg / 3.5cwt
Personal Effects	156kg / 3.1cwt	180kg / 3.5cwt	180kg / 3.5cwt
Options	0kg / 0.0cwt	0kg / 0cwt	0kg / 0cwt
Tyre Size	195/70 R15C 104 R	185 / 70 R14 88T	185 / 70 R14 88T
Tyre pressure at Lower limit MTPLM	4.3 bar / 62 psi	2.1 bar / 30 psi	2.1 bar / 30 psi
Tyre pressure at Upper limit MTPLM	4.5 bar / 65 psi	2.2 bar / 32 psi	2.2 bar / 32 psi
Static Load on Coupling Head	100kg	100kg	100kg
Thermal Insulation Grade	THREE	THREE	THREE
Bed Sizes			
Front Double	225cm x 163cm / 7'4" x 5'4"	225cm x 180cm / 7'4" x 5'11"	225cm x 180cm / 7'4" x 5'11"
or Front Nearside Single	163cm x 73cm / 5'4" x 2'5"	180cm x 73cm / 5'11" x 2'5"	180cm x 73cm / 5'11" x 2'5"
and Front Offside Single	163cm x 73cm / 5'4" x 2'5"	180cm x 73cm / 5'11" x 2'5"	180cm x 73cm / 5'11" x 2'5"
Rear Double	185cm x 133cm / 6'1" x 4'4"	196cm x 135cm / 6'5" x 4'5"	
Side Double (offside)		190cm x 134cm / 6'3" x 4'5"	190cm x 134cm / 6'3" x 4'5"
Side Fixed Lower Bunk			182cm x 72cm x 6'0" x 2'4"
Side Fixed Upper Bunk			182cm x 72cm x 6'0" x 2'4"

Masses: The masses are calculated in accordance to EU regulation 1230 / 2012 and NCC code of practice 304.

The Mass in Running Order (MRO) comprises:

1. The mass of the empty caravan as supplied by Swift including loose items such as the hook-up cable, kit bag, entrance step, manuals etc.
2. 10kg allowance for LPG

The MRO is calculated with the fresh water tank, toilet flush tank and water heater empty. If you travel with water in the fresh water tank, toilet flush tank and the water heater the payload will reduce accordingly.

The personal effects is based on the number of berths and the length of the caravan and includes an allowance of 20kg for a leisure battery.

The Maximum Technical Laden Mass (MTPLM) is the maximum mass allowed when the caravan is fully laden.

WARNING: Under no circumstances should the MTPLM be exceeded

Bed Sizes: Please note that the front double bed sizes quoted are for seating configurations without chest of drawers. The front double bed width for a layout with a chest of drawers fitted will be reduced by 0.4m (1'4") from that stated.

Awning sizes: Due to the varying awning designs and sizes the awning sizes given are approximate only. Specific awning sizes must be confirmed by your dealer or the awning manufacturer prior to purchase.

Est = Estimated weight or bed size

**The dimensions given are approximate due to slight variations in suspension ride heights, loading conditions and tyre pressures.

Customers should verify the actual dimensions of their touring caravan before committing to anything that could be impacted by these dimensions

Please note: Any dealer fit options will reduce the overall payload available to the user of the caravan.

If you require additional payload it is possible to upgrade the MTPLM to the upper limit. Please contact your caravan dealer for more information.

Dealer Special specifications based on Challenger

Based on Challenger	480	530	560
Dealer			
BROADLANE	PLATINUM FAIRWAY 480	PLATINUM FAIRWAY 530	PLATINUM FAIRWAY 560
LOWDHAM	HI-STYLE 480		HI-STYLE 560
WANDAHOME	CORNICHE 16/2	CORNICHE 17/4	CORNICHE 19/4
3A's	GTS 480		GTS 560
GLOSSOP	CELEBRATION 480	CELEBRATION 530	CELEBRATION 560
KIMBERLEY	TREND 480		TREND 560
GRANTHAM	ELITE 480	ELITE 530	ELITE 560
Berths	2	4	4
Axles	1	1	1
Internal Length (bed box height)	4.95m / 16'3"	5.29m / 17'4"	5.83m / 19'2"
Overall Width**	2.23m / 7'4"	2.23m / 7'4"	2.23m / 7'4"
Overall Height (inc. TV Aerial)**	2.61m / 8'7"	2.61m / 8'7"	2.61m / 8'7"
Maximum Internal Headroom	1.95m / 6'5"	1.95m / 6'5"	1.95m / 6'5"
Overall Length**	6.66m / 21'10"	7.00m / 23'0"	7.54m / 24'9"
Awning A / A dimension	9.32m / 30'7"	9.66m / 31'8"	10.20m / 33'6"
Mass in Running Order (inc. tolerance)	1307kg / 25.7cwt	1375kg / 27.1cwt	1464kg / 28.8cwt
Maximum Technical Permissible Laden Mass (Lower limit)	1434kg / 28.2cwt	1526kg / 30.0cwt	1620kg / 31.9cwt
Maximum Technical Permissible Laden Mass (Upper limit)	1500kg / 29.5cwt	1550kg / 30.5cwt	1650kg / 32.5cwt
Total user Payload	127kg / 2.5cwt	151kg / 3.0cwt	156kg / 3.1cwt
Personal Effects	127kg / 2.5cwt	151kg / 3.0cwt	156kg / 3.1cwt
Options	0kg / 0cwt	0kg / 0cwt	0kg / 0cwt
Tyre Size	185 R14C 102Q	185 R14C 102Q	195 / 70 R15C 104R
Tyre pressure at Lower limit MTPLM	4.1 bar / 59 psi	4.5 bar / 65 psi	4.5 bar / 65 psi
Tyre pressure at Upper limit MTPLM	4.4 bar / 64 psi	4.5 bar / 65 psi	4.5 bar / 65 psi
Static Load on Coupling Head	100kg	100kg	100kg
Thermal Insulation Grade	THREE	THREE	THREE
Bed Sizes			
Front Double	202cm x 186cm / 6'8" x 6'1"	202cm x 176cm / 6'8" x 5'9"	202cm x 156cm / 6'8" x 5'1"
or Front Nearside Single	196cm x 72cm / 6'4" x 2'4"	176cm x 72cm / 5'9" x 2'4"	156cm x 72cm / 5'1" x 2'4"
and Front Offside Single	186cm x 72cm / 6'1" x 2'4"	186cm x 72cm / 6'1" x 2'4"	156cm x 72cm / 5'1" x 2'4"
Rear Double			190cm x 133cm / 6'3" x 4'4"
Side Single (offside)		180cm x 62cm / 5'11" x 2'0"	
Side Single (nearside)			
Side Bunk (offside)		176cm x 59cm / 5'9" x 1'11"	

Masses: The masses are calculated in accordance to EU regulation 1230 / 2012 and NCC code of practice 304.

The Mass in Running Order (MRO) comprises:

1. The mass of the empty caravan as supplied by Swift including loose items such as the hook-up cable, kit bag, entrance step, manuals etc.
2. 10kg allowance for LPG

The MRO is calculated with the fresh water tank, toilet flush tank and water heater empty. If you travel with water in the fresh water tank, toilet flush tank and the water heater the payload will reduce accordingly.

The personal effects is based on the number of berths and the length of the caravan and includes an allowance of 20kg for a leisure battery.

The Maximum Technical Laden Mass (MTPLM) is the maximum mass allowed when the caravan is fully laden.

WARNING: Under no circumstances should the MTPLM be exceeded

580	650
PLATINUM FAIRWAY 580	PLATINUM FAIRWAY 650
HI-STYLE 580	
CORNICHE 20/4	CORNICHE 23/4
GTS 580	
CELEBRATION 580	CELEBRATION 650
TREND 580	
ELITE 580	ELITE 650
4	4
1	2
5.83m / 19'2"	6.27m / 20'7"
2.23m / 7'4"	2.23m / 7'4"
2.61m / 8'7"	2.61m / 8'7"
1.95m / 6'5"	1.95m / 6'5"
7.54m / 24'9"	7.98m / 26'2"
10.20m / 33'6"	10.52m / 34'6"
1437kg / 28.3cwt	1589kg / 30.9cwt
1593kg / 31.4cwt	1749kg / 34.4cwt
1650kg / 32.5cwt	2000kg / 39.4cwt
156kg / 3.1cwt	160kg / 3.1cwt
156kg / 3.1cwt	160kg / 3.1cwt
0kg / 0cwt	0kg / 0cwt
195 / 70 R15C 104R	185 / 70 R14 88T
4.5 bar / 65 psi	2.1 bar / 30 psi
4.5 bar / 65 psi	2.5 bar / 36 psi
100kg	100kg
THREE	THREE
202cm x 156cm / 6'8" x 5'1"	202cm x 156cm / 6'8" x 5'1"
156cm x 72cm / 5'1" x 2'4"	156cm x 72cm / 5'1" x 2'4"
156cm x 72cm / 5'1" x 2'4"	156cm x 72cm / 5'1" x 2'4"
185cm x 133cm / 6'1" x 4'4"	185cm x 133cm / 6'1" x 4'4"

Bed Sizes: Please note that the front double bed sizes quoted are for seating configurations without chest of drawers. The front double bed width for a layout with a chest of drawers fitted will be reduced by 0.4m (1'4") from that stated.

Awning sizes: Due to the varying awning designs and sizes the awning sizes given are approximate only. Specific awning sizes must be confirmed by your dealer or the awning manufacturer prior to purchase.

Est = Estimated weight or bed size

**The dimensions given are approximate due to slight variations in suspension ride heights, loading conditions and tyre pressures.

Customers should verify the actual dimensions of their touring caravan before committing to anything that could be impacted by these dimensions

Please note: Any dealer fit options will reduce the overall payload available to the user of the caravan.

If you require additional payload it is possible to upgrade the MTPLM to the upper limit. Please contact your caravan dealer for more information.

Dealer Special specifications based on Challenger X

Based on Challenger X	860	880	835
Dealer			
BROADLANE	FAIRWAY PLATINUM 860	FAIRWAY PLATINUM 880	FAIRWAY PLATINUM 835
LOWDHAM	HI-STYLE 860	HI-STYLE 880	HI-STYLE 835
WANDAHOME	CORNICHE 19/8	CORNICHE 20/8	CORNICHE 21/8
3A's	GTS X 860	GTS X 880	GTS X 835
GLOSSOP	CELEBRATION 860	CELEBRATION 880	CELEBRATION 835
KIMBERLEY	TREND X 860	TREND X 880	TREND X 835
GRANTHAM	ELITE 860	ELITE 880	ELITE 835
Berths	4	4	4
Axles	1	1	2
Internal Length (bed box height)	5.83m / 19'2"	5.83m / 19'2"	6.27m / 20'7"
Overall Width**	2.45m / 8'0"	2.45m / 8'0"	2.45m / 8'0"
Overall Height (inc. TV Aerial)**	2.61m / 8'7"	2.61m / 8'7"	2.59m / 8'6"
Maximum Internal Headroom	1.95m / 6'5"	1.95m / 6'5"	1.95m / 6'5"
Overall Length**	7.54m / 24'9"	7.54m / 24'9"	7.98m / 26'2"
Awning A / A dimension	10.20m / 33'6"	10.20m / 33'6"	10.52m / 34'6"
Mass in Running Order (inc. tolerance)	1554kg / 30.6cwt	1510kg / 29.7cwt	1671kg / 32.9cwt
Maximum Technical Permissible Laden Mass (Lower limit)	1710kg / 33.7cwt	1666kg / 32.8cwt	1831kg / 36.0cwt
Maximum Technical Permissible Laden Mass (Upper limit)	1750kg / 34.4cwt	1750kg / 34.4cwt	2000kg / 39.4cwt
Total user Payload	156kg / 3.1cwt	156kg / 3.1cwt	160kg / 3.1cwt
Personal Effects	156kg / 3.1cwt	156kg / 3.1cwt	160kg / 3.1cwt
Options	0.0kg / 0cwt	0.0kg / 0cwt	0.0kg / 0cwt
Tyre Size	195 / 70 R15C 104 R	195 / 70 R15C 104 R	185 / 70 R14 88 T
Tyre pressure at Lower limit MTPLM	4.5 bar / 65 psi	4.5 bar / 65 psi	2.3 bar / 33 psi
Tyre pressure at Upper limit MTPLM	4.5 bar / 65 psi	4.5 bar / 65 psi	2.5 bar / 36 psi
Static Load on Coupling Head	100kg	100kg	100kg
Thermal Insulation Grade	THREE	THREE	THREE
Bed Sizes			
Front Double	197cm x 127cm / 6'6" x 4'2"	225cm x 159cm / 7'4" x 5'3"	225cm x 159cm / 7'4" x 5'3"
or Front Nearside Single		159cm x 73cm / 5'3" x 2'5"	159cm x 73cm / 5'3" x 2'5"
and Front Offside Single		159cm x 73cm / 5'3" x 2'5"	159cm x 73cm / 5'3" x 2'5"
Rear Double	187cm x 143cm / 6'2" x 4'8"	187cm x 133cm / 6'2" x 4'4"	187cm x 133cm / 6'2" x 4'4"
Side Single (offside)			
Side Single (nearside)			

Masses: The masses are calculated in accordance to EU regulation 1230 / 2012 and NCC code of practice 304.

The Mass in Running Order (MRO) comprises:

1. The mass of the empty caravan as supplied by Swift including loose items such as the hook-up cable, kit bag, entrance step, manuals etc.
2. 10kg allowance for LPG

The MRO is calculated with the fresh water tank, toilet flush tank and water heater empty. If you travel with water in the fresh water tank, toilet flush tank and the water heater the payload will reduce accordingly.

The personal effects is based on the number of berths and the length of the caravan and includes an allowance of 20kg for a leisure battery.

The Maximum Technical Laden Mass (MTPLM) is the maximum mass allowed when the caravan is fully laden.

WARNING: Under no circumstances should the MTPLM be exceeded

850
FAIRWAY PLATINUM 850
HI-STYLE 850
CORNICHE 23/8
GTS X 850
CELEBRATION 850
TREND X 850
ELITE 850
4
2
6.27m / 207"
2.45m / 8'0"
2.59m / 8'6"
1.95m / 6'5"
7.98m / 26'2"
10.52m / 34'6"
1679kg / 33.1cwt
1839kg / 36.2cwt
2000kg / 39.4cwt
160kg / 3.1cwt
160kg / 3.1cwt
0.0kg / 0cwt
185 / 70 R14 88 T
2.2 bar / 32 psi
2.5 bar / 36 psi
100kg
THREE
197cm x 127cm / 6'6" x 4'2"
187cm x 143cm / 6'2" x 4'8"

Bed Sizes: Please note that the front double bed sizes quoted are for seating configurations without chest of drawers. The front double bed width for a layout with a chest of drawers fitted will be reduced by 0.4m (1'4") from that stated.

Awning sizes: Due to the varying awning designs and sizes the awning sizes given are approximate only. Specific awning sizes must be confirmed by your dealer or the awning manufacturer prior to purchase.

Est = Estimated weight or bed size

**The dimensions given are approximate due to slight variations in suspension ride heights, loading conditions and tyre pressures.

Customers should verify the actual dimensions of their touring caravan before committing to anything that could be impacted by these dimensions

Please note: Any dealer fit options will reduce the overall payload available to the user of the caravan.

If you require additional payload it is possible to upgrade the MTPLM to the upper limit. Please contact your caravan dealer for more information.

Dealer Special specification based on Conqueror

Based on Conqueror	480	580
Dealer		
COUPLANDS	CAMEO BY DESIGN 495	CAMEO BY DESIGN 580
Berths	2	4
Axles	1	1
Internal Length (bed box height)	4.98m / 16'4"	5.93m / 19'5"
Overall Width*	2.28m / 7'6"	2.28m / 7'6"
Overall Height (inc. TV Aerial)*	2.59m / 8'6"	2.61m / 8'7"
Maximum Internal Headroom	1.95m / 6'5"	1.95m / 6'5"
Overall Length*	6.59m / 21'7"	7.54m / 24'9"
Awning A / A dimension	9.28m / 30'5"	10.30m / 33'10"
Mass in Running Order (inc. tolerance)	1451kg / 28.6cwt	1585kg / 31.2cwt
Maximum Technical Permissible Laden Mass (Lower limit)	1577kg / 31.0cwt	1741kg / 34.3cwt
Maximum Technical Permissible Laden Mass (Upper limit)	1750kg / 34.4cwt	1800kg / 35.4cwt
Total user Payload	126kg / 2.5cwt	156kg / 3.1cwt
Personal Effects	126kg / 2.5cwt	156kg / 3.1cwt
Options	0.0kg / 0.0cwt	0.0kg / 0.0cwt
Tyre Size	195 / 70 R15C 104 R	205 / 70 R15C 106 R
Tyre pressure at Lower limit MTPLM	4.3 bar / 62 psi	4.5 bar / 65 psi
Tyre pressure at Upper limit MTPLM	4.5 bar / 65 psi	4.5 bar / 65 psi
Static Load on Coupling Head	100kg	100kg
Thermal Insulation Grade	THREE	THREE
Bed Sizes		
Front Double	200cm x 186cm / 6'7" x 6'1"	200cm x 168cm / 6'7" x 5'6"
or Front Nearside Single and Front Offside Single	181cm x 67cm / 5'11" x 2'2"	
Rear Double		182cm x 133cm / 6'0" x 4'4"
Side Single (offside)		
Side Single (nearside)		

Masses: The masses are calculated in accordance to EU regulation 1230 / 2012 and NCC code of practice 304.

The Mass in Running Order (MRO) comprises:

1. The mass of the empty caravan as supplied by Swift including loose items such as the hook-up cable, kit bag, entrance step, manuals etc.
2. 10kg allowance for LPG

The MRO is calculated with the fresh water tank, toilet flush tank and water heater empty. If you travel with water in the fresh water tank, toilet flush tank and the water heater the payload will reduce accordingly.

The personal effects is based on the number of berths and the length of the caravan and includes an allowance of 20kg for a leisure battery.

The Maximum Technical Laden Mass (MTPLM) is the maximum mass allowed when the caravan is fully laden.

WARNING: Under no circumstances should the MTPLM be exceeded

Bed Sizes: Please note that the front double bed sizes quoted are for seating configurations without chest of drawers. The front double bed width for a layout with a chest of drawers fitted will be reduced by 0.4m (1'4") from that stated.

Awning sizes: Due to the varying awning designs and sizes the awning sizes given are approximate only. Specific awning sizes must be confirmed by your dealer or the awning manufacturer prior to purchase.

Est = Estimated weight or bed size

**The dimensions given are approximate due to slight variations in suspension ride heights, loading conditions and tyre pressures.

Customers should verify the actual dimensions of their touring caravan before committing to anything that could be impacted by these dimensions

Please note: Any dealer fit options will reduce the overall payload available to the user of the caravan.

If you require additional payload it is possible to upgrade the MTPLM to the upper limit. Please contact your caravan dealer for more information.

Dealer Special specification based on Elegance

Based on Elegance	Elegance Grande 835	Elegance Grande 845	Elegance Grande 850
Dealer			
COUPLANDS	CAMEO BY DESIGN 835	CAMEO BY DESIGN 845	CAMEO BY DESIGN 850
Berths	4	4	4
Axles	2	2	2
Internal Length (bed box height)	6.36m / 20'10"	6.36m / 20'10"	6.36m / 20'10"
Overall Width*	2.45m / 8'0"	2.45m / 8'0"	2.45m / 8'0"
Overall Height (inc. TV Aerial)*	2.59m / 8'6"	2.59m / 8'6"	2.59m / 8'6"
Maximum Internal Headroom	1.95m / 6'5"	1.95m / 6'5"	1.95m / 6'5"
Overall Length*	7.98m / 26'2"	7.98m / 26'2"	7.98m / 26'2"
Awning A / A dimension	10.49m / 34'5"	10.49m / 34'5"	10.49m / 34'5"
Mass in Running Order (inc. tolerance)	1818kg / 35.8cwt	1783kg / 35.1cwt	1813kg / 35.7cwt
Maximum Technical Permissible Laden Mass (Lower limit)	1978kg / 38.9cwt	1943kg / 38.2cwt	1973kg / 38.8cwt
Maximum Technical Permissible Laden Mass (Upper limit)	2000kg / 39.4cwt	2000kg / 39.4cwt	2000kg / 39.4cwt
Total user Payload	160kg / 3.1cwt	160kg / 3.1cwt	160kg / 3.1cwt
Personal Effects	160kg / 3.1cwt	160kg / 3.1cwt	160kg / 3.1cwt
Options	0.0kg / 0.0cwt	0.0kg / 0.0cwt	0.0kg / 0.0cwt
Tyre Size	185 / 70 R14 88 T	185 / 70 R14 88 T	185 / 70 R14 88 T
Tyre pressure at Lower limit MTPLM	2.5 bar / 36 psi	2.4 bar / 35 psi	2.4 bar / 35 psi
Tyre pressure at Upper limit MTPLM	2.5 bar / 36 psi	2.5 bar / 36 psi	2.5 bar / 36 psi
Static Load on Coupling Head	100kg	100kg	100kg
Thermal Insulation Grade	THREE	THREE	THREE
Bed Sizes			
Front Double	218cm x 153cm / 7'2" x 5'0"	218cm x 153cm / 7'2" x 5'0"	194cm x 121cm / 6'4" x 4'0"
Side Double drop down or Front Nearside Single and Front Offside Single	153cm x 70cm / 5'0" x 2'4" 153cm x 70cm / 5'0" x 2'4"	153cm x 70cm / 5'0" x 2'4" 153cm x 70cm / 5'0" x 2'4"	
Rear Double	184cm x 133cm / 6'0" x 4'4"	184cm x 133cm / 6'0" x 4'4"	189cm x 143cm / 6'2" x 4'8"

Masses: The masses are calculated in accordance to EU regulation 1230 / 2012 and NCC code of practice 304.

The Mass in Running Order (MRO) comprises:

1. The mass of the empty caravan as supplied by Swift including loose items such as the hook-up cable, kit bag, entrance step, manuals etc.
2. 10kg allowance for LPG

Bed Sizes: Please note that the front double bed sizes quoted are for seating configurations without chest of drawers. The front double bed width for a layout with a chest of drawers fitted will be reduced by 0.4m (14") from that stated.

Awning sizes: Due to the varying awning designs and sizes the awning sizes given are approximate only. Specific awning sizes must be confirmed by your dealer or the awning manufacturer prior to purchase.

The MRO is calculated with the fresh water tank, toilet flush tank and water heater empty. If you travel with water in the fresh water tank, toilet flush tank and the water heater the payload will reduce accordingly.

The personal effects is based on the number of berths and the length of the caravan and includes an allowance of 20kg for a leisure battery.

Est = Estimated weight or bed size

**The dimensions given are approximate due to slight variations in suspension ride heights, loading conditions and tyre pressures.

Customers should verify the actual dimensions of their touring caravan before committing to anything that could be impacted by these dimensions

Please note: Any dealer fit options will reduce the overall payload available to the user of the caravan.

The Maximum Technical Laden Mass (MTPLM) is the maximum mass allowed when the caravan is fully laden.

WARNING: Under no circumstances should the MTPLM be exceeded

If you require additional payload it is possible to upgrade the MTPLM to the upper limit. Please contact your caravan dealer for more information.

Bed make up

Bed make up in Basecamp front end

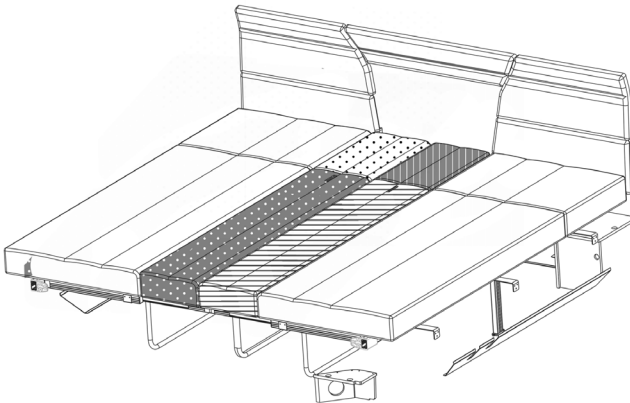
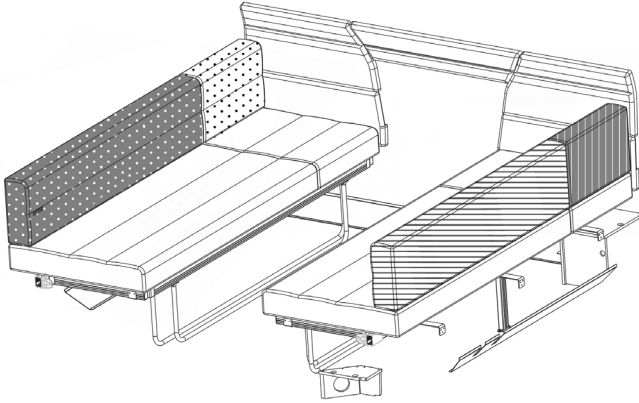

Bed make up

Bunk bed make up in Basecamp 4 /6

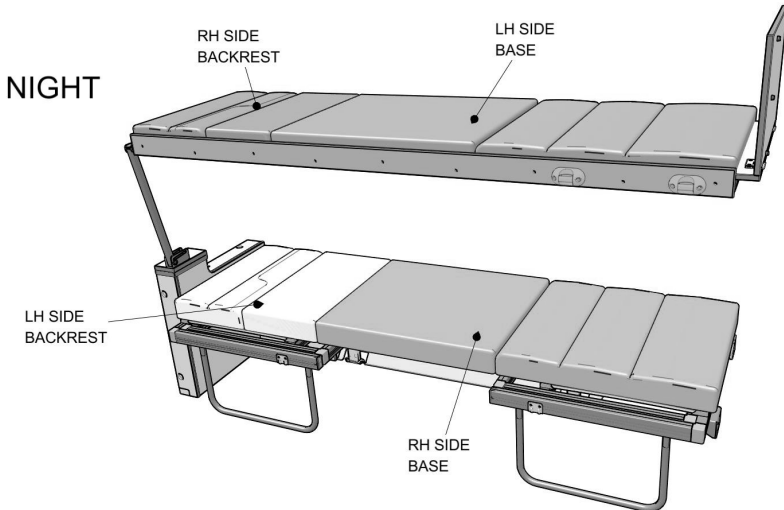
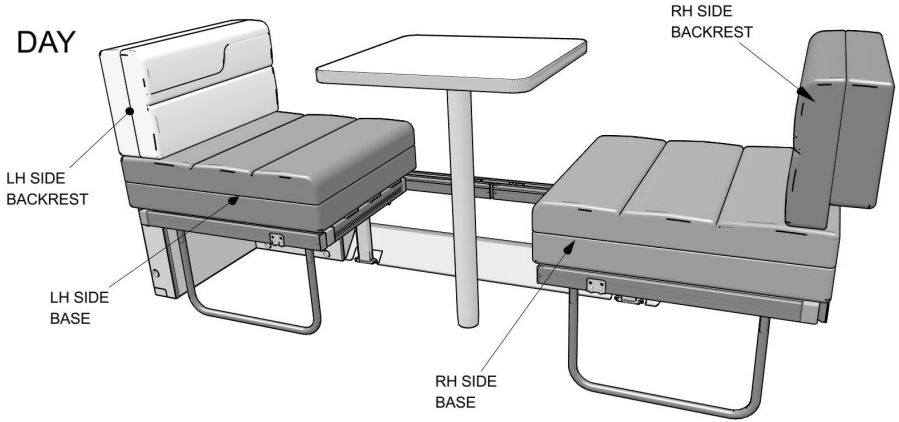

Bed make up

Bed make up in Quattro EW and Challenger 530 mid bed

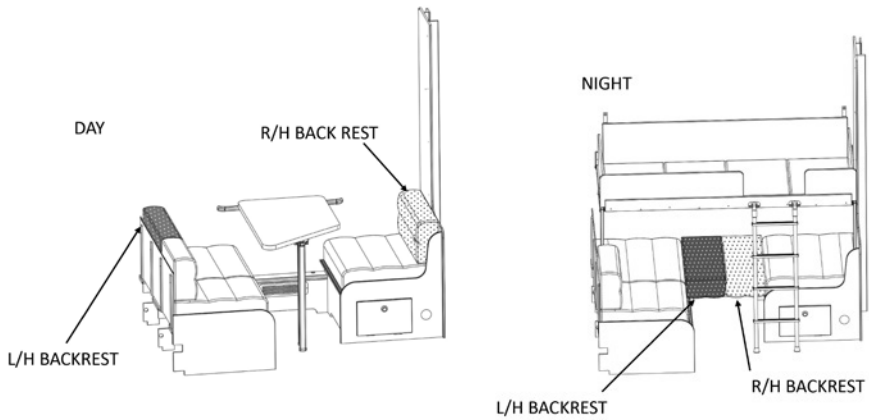
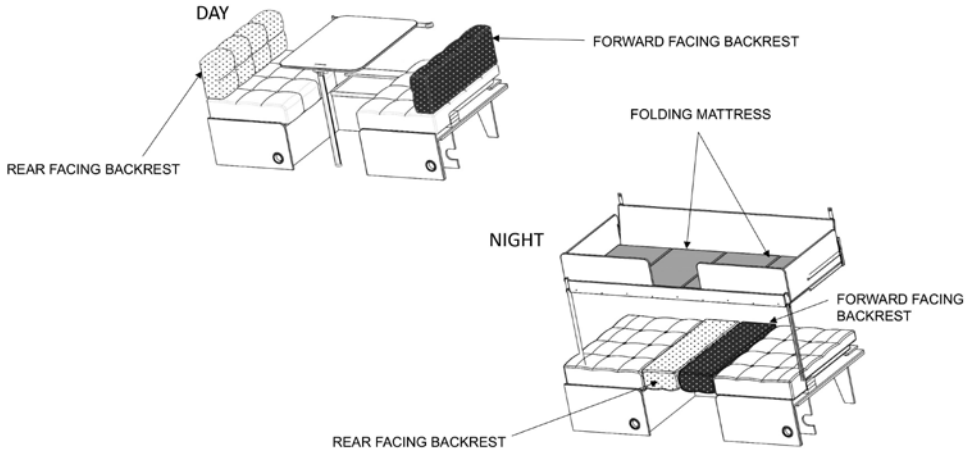

Bed make up

Bed make up in Sprite Super, Challenger X and Elegance

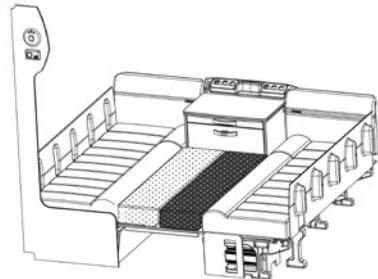
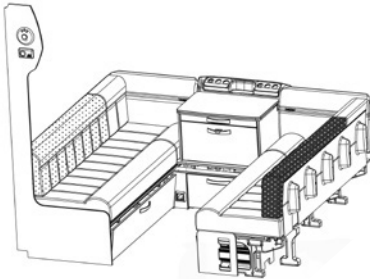
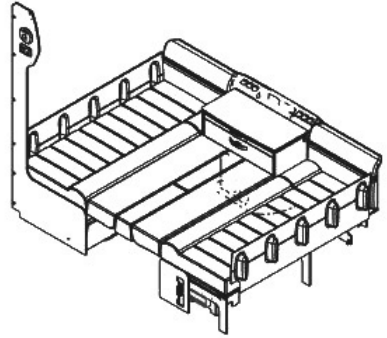
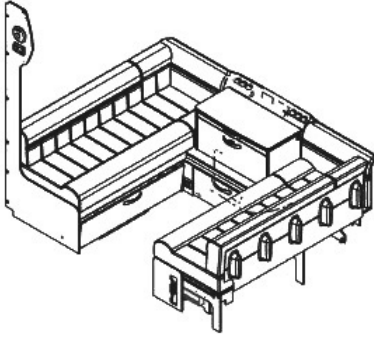

Bed make up

Bed make up in Challenger, Challenger X, Elegance 850 front bed

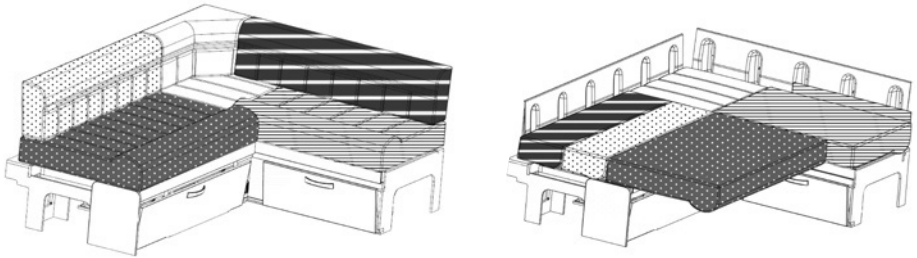

Bed make up in Sprite Super mid bed

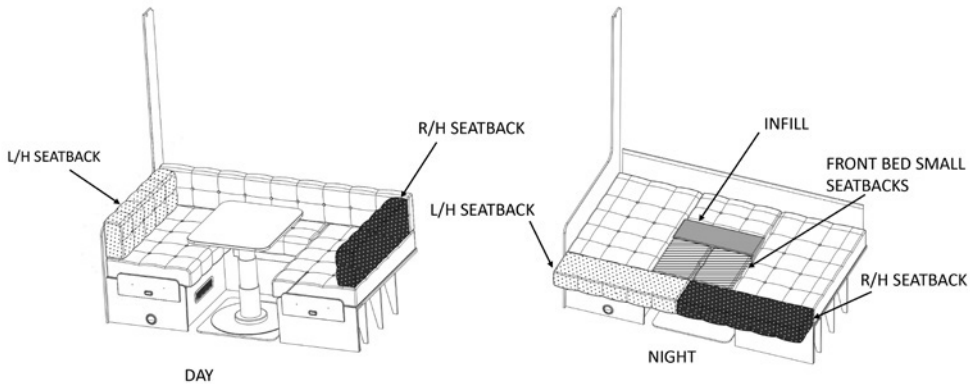









SWIFT
CREATING SMILES FOR LIFE

Dunswell Road
Cottingham
East Yorkshire
HU16 4JX

Tel: 01482 875740

Fax: 01482 840082

Customer Experience Team

enquiries@swiftleisure.co.uk

FIND OUT MORE AT **SWIFTGROUP.CO.UK**



Brochure



Layouts



Dealer



Video



Social